

3 FT POWER CORD ARE SUPPLIED WITH 1.5 kW (115V) & 2 kW (230V) HEATERS ONLY

**NOTE:** IT IS RECOMMENDED THAT ALL HEATERS LARGER THAN 2 KW BE HARD WIRED TO THE ELECTRICAL SUPPLY BY A QUALIFIED ELECTRICIAN.

1.5 KW HEATERS SUPPLIED WITH #5-20P 115V PLUG

2 KW HEATERS SUPPLIED WITH #6-15P 220V PLUG

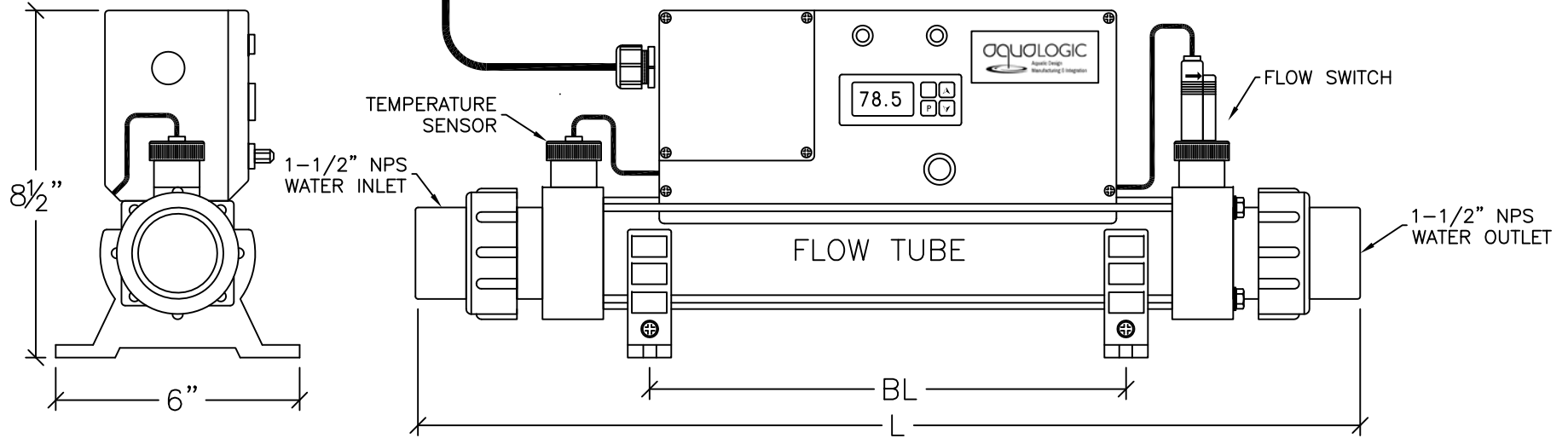

**INLINE HEATER SPECIFICATIONS**

MODEL	KW	VOLTS	PHASE	AMPS	L	BL
HSS-1.5-115	1.5	115	1	13	23"	12.5"
HSS-2-115	2	115	1	17.4	23"	12.5"
HSS-2-220	2	220	1	9	23"	12.5"
HSS-3-220	3	220	1	13.6	23"	12.5"
HTI-1.5-115	1.5	115	1	13	23"	12.5"
HTI-2-115	2	115	1	17.4	23"	12.5"
HTI-2-220	2	220	1	9	23"	12.5"
HTI-3-220	3	220	1	13.6	23"	12.5"
HTI-4-220	4	220	1	18	23"	12.5"

HSS- 316 STAINLESS STEEL MODELS  
HTI- PURE TITANIUM MODELS

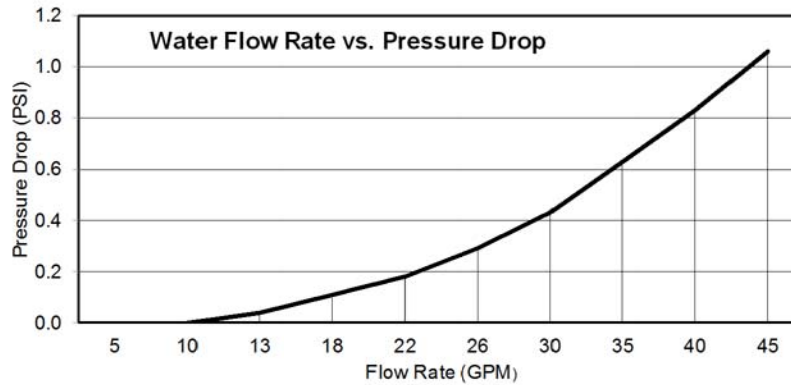

MINIMUM WATER FLOW RATE FOR ALL HEATERS: 10 GPM (600 GPH)  
MAXIMUM WATER FLOW RATE FOR ALL HEATERS: 44 GPM (2640 GPH)

	Aqua Logic, Inc. 9558 Camino Ruiz San Diego, CA. 92019		
	TITLE: 1.5 KW THRU 4 KW INLINE HEATERS		
LAST UPDATE: 11-13-15	DATE: 7-25-07	FILE: ELECRO HEATER	BY CE