



Other products manufactured and distribute by Aqua Logic, Inc.



Water to water and refrigerant to water heat exchangers



Water UV Sterilizers



Water chillers and Heat pumps



Inline water Natural Gas or Propane boiler / heat exchanger package systems heaters for saltwater and freshwater

Titanium and Stainless Steel Aquatic Heater



Installation Instructions & Operating Manual

USA Version 1/16

Please Read Carefully Before Installing

Incorrect Installation Will Effect Your Warranty

Do Not Discard, Keep For Future Reference

Table of Contents

Page	
1	Positioning of Heater
2	Pipe work (Plumbing installation)
3	Electrical Connection and Power Requirements
4	Flow Requirements
5	Pressure vs. water flow chart / Water Quality
6	Digital Thermostat Instructions
7	Operating Your Heater
8	Trouble Shooting
9	Trouble Shooting Continued
10	Replacement Parts
11	Heater Parts Drawing
12	Heater Specifications
13	Aqua Logic Products
14	Guarantee (Back cover)

GUARANTEE

Your Elecro heater is guaranteed for one year from the date of purchase against faulty workmanship and materials.

AQUALOGIC INC. will replace or repair, at our discretion, any faulty units or components returned to the company for inspection. Proof of purchase may be required.

AQUA LOGIC INC. and or ELECRO ENGINEERING LTD will not be liable in cases of incorrect installation of the heater, or inappropriate use, or neglect of the heater.

CE Declaration Of Conformity

Elecro declares that the herewith products or ranges.

ELECTRIC AQUATIC HEATER RANGE

Are in conformity with the provisions of the ELECTROMAGNETIC COMPATIBILITY directive 89/336/EEC, as amended 93/068/EEC. Controlled by AEMC Measures laboratory technical report no P96045T

The harmonized standards have been applied: EN 55014—EN 55104, EN 55011, EN 55022, CEI 801-4, CEI 801-2, CEI 801-3 of the LOW VOLT-AGE directive 73/23/EEC.

The harmonized standards have been applied **EN 60335-2-35**



USA, Mexico and Canada Distributor

AQUA LOGIC, INC.
9558 Camino Ruiz
San Diego, California 92126 USA

Tel: 858.292.4773 Fax: 858.279.0537

Website: www.aqualogicinc.com Email: info@aqualogicinc.com

© Copyright 2015 Aqua Logic, Inc.

ELECRO ENGINEERING LTD

Unit 14, Leyden Road,
Stevenage, Hertfordshire SG1 2BW UK

Tel: +44 (0)1438 749 474 Fax: +44 (0)1438 361 329
Website: www.elecro.co.uk E-mail: info@elecro.co.uk

NOTE: IT IS RECOMMENDED THAT ALL HEATERS LARGER THAN 2 KW BE HARD WIRED TO THE ELECTRICAL SUPPLY BY A QUALIFIED ELECTRICIAN.

3 FT. POWER CORD ARE SUPPLIED WITH 1.5 KW (115V) & 2 KW (230V) HEATERS ONLY

1.5 KW HEATERS SUPPLIED WITH #8-20P 115V PLUG

2 KW HEATERS SUPPLIED WITH #6-15P 220V PLUG

3 FT. POWER CORD ARE SUPPLIED WITH 1.5 KW (115V) & 2 KW (230V) HEATERS ONLY

1.5 KW HEATERS SUPPLIED WITH #8-20P 115V PLUG

2 KW HEATERS SUPPLIED WITH #6-15P 220V PLUG

TEMPERATURE SENSOR

1-1/2" NPS WATER INLET

FLOW SWITCH

1-1/2" NPS WATER OUTLET

FLOW TUBE

BL

6"

8 1/2"

Water Flow Rate vs. Pressure Drop

INLINE HEATER SPECIFICATIONS					
MODEL	KW	VOLTS	PHASE	AMPS	BL
HSS-1.5-115	1.5	115	1	13	23"
HSS-2-115	2	115	1	17.4	23"
HSS-2-220	2	220	1	9	23"
HSS-3-220	3	220	1	13.6	23"
HTI-1.5-115	1.5	115	1	13	23"
HTI-2-115	2	115	1	17.4	23"
HTI-2-220	2	220	1	9	23"
HTI-3-220	3	220	1	13.6	23"
HTI-4-220	4	220	1	18	23"

HSS- 316 STAINLESS STEEL MODELS
HTI- PURE TITANIUM MODELS

MINIMUM WATER FLOW RATE FOR ALL HEATERS: 10 GPM (600 GPH)
MAXIMUM WATER FLOW RATE FOR ALL HEATERS: 44 GPM (2640 GPH)

AquaLogic
9555 Camino Ruiz
San Diego, CA 92019

TITLE: 1.5 KW THRU 4 KW
INLINE HEATERS

FILE/ELECR0 HEATER

LAST UPDATE: 11-13-15 | DATE: 7-25-07

Positioning

Your Elecro heater must be screw fixed to a firm base or wall. The heater **MUST** be horizontal and upright i.e. with the control enclosure located above the Titanium or Stainless steel flow tube (see diagram below). Under no circumstances should the heater be operated in any other orientation.

ALL HEATERS MUST BE MOUNTED HORIZONTALLY i.e. WITH CONTROL BOX UPPERMOST.

TO ALTER MOUNTING CARRIERS

WALL MOUNTED

FACORY SET

- UNDO CARRIER/SET FOOT BOLT
- RE CLAMP AT REAR OF STAINLESS STEEL TANK

TO ACCESS ELECTRICAL CONNECTIONS - (QUALIFIED ELECTRICIANS)

Diagrams do not show the digital thermostat

The heater can be installed on both pump and gravity fed systems. It should be installed at a low point in the filtration system. To limit weed and debris build up inside the heater it **must** be located after the filter.

NOTE: If the flow direction is reversed (explained later in this booklet) the heater **MUST** remain sited after the filter.

Only clean filtered water should enter the heater.

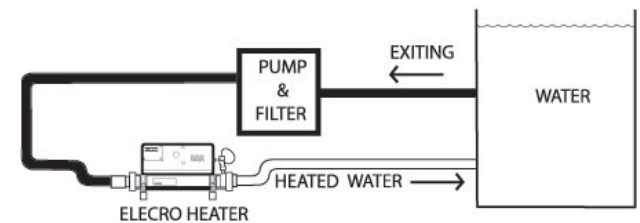

Pipe Work

It is essential that the pipe work connecting to and from the heater has a minimum of 1-1/2" pipe size.

To assist correct air purging and to ensure the heater remains completely full of water during operation, the return pipe which carries the water back to the tank or pond must incorporate a safety loop or kick up in the pipe, installed as close as possible to the heater (see diagram below). For maintenance purposes we suggest installing isolation ball valves on the water in and outlet side.

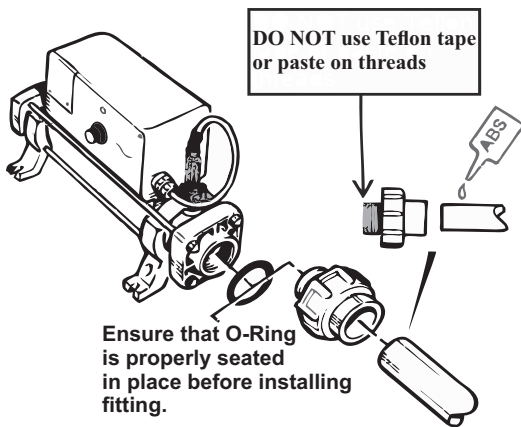
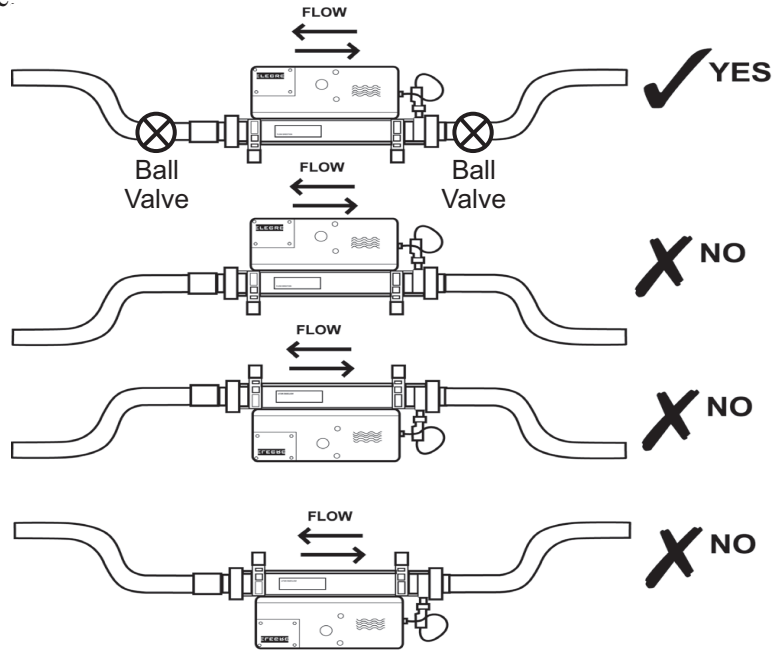

2

Heater Parts Drawing

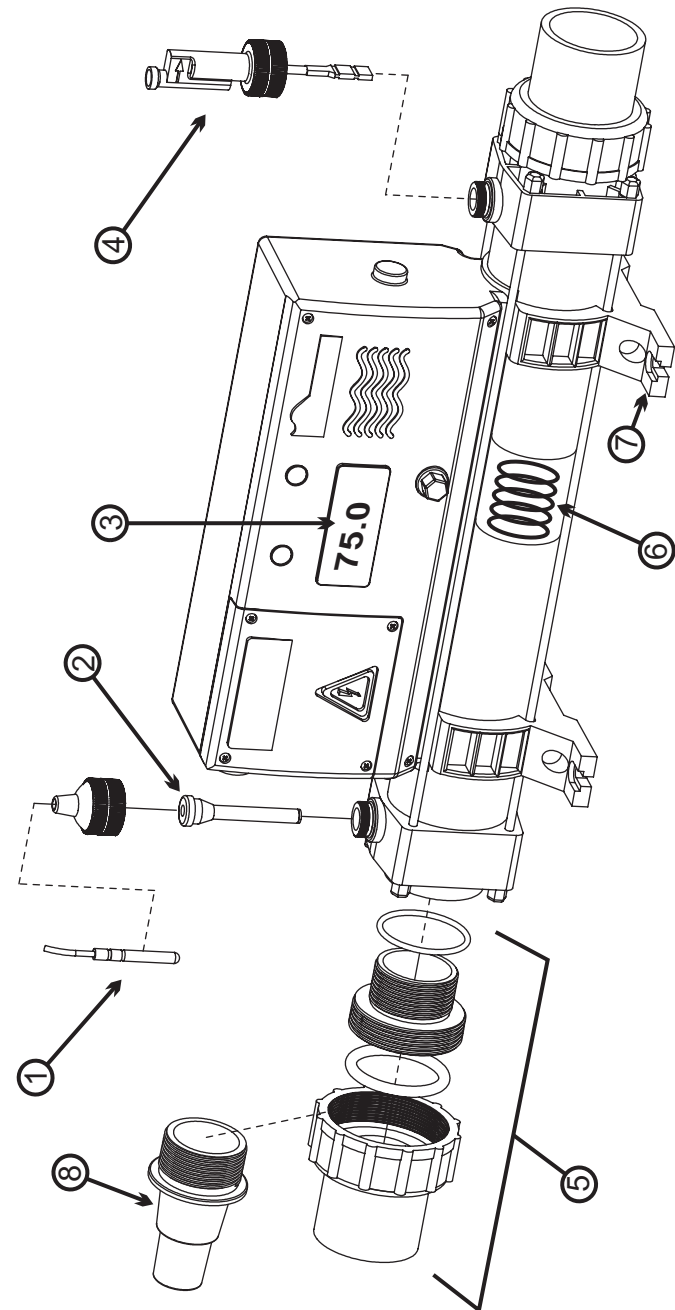

11

Weather Protection

The heater should be installed within a dry weatherproof enclosure if located outdoors.

CAUTION

If the heater is not used during winter months it must be drained to prevent freeze damage.

NOTE: To allow ease of periodic internal cleaning - it is recommended that the heater is installed with ball valve unions on both water input and output sides. This will allow the water to be shut off on both sides of the heater to allow removal from the system.

Electrical Connection

The heater must be installed in accordance with the country /regional requirements regulations. It is recommend that the 2 kW 115v and all 3 kW be hard wired to the electrical supply by a qualified electrician. The power supply **must** be fitted with a GFIC (Ground Fault Interruption Circuit)

Note: 2 kW 115 volt models and 3 kW and larger heaters are **NOT** supplied with power cords.

Replacement Parts List

REF #	QTY	DESCRIPTION	PART NO.
1	1	Temperature Control Sensor	HTR-PART-09
2	1	Control Sensor Dry Well	HTR-PART-18
3	1	Temperature Controller	HTR-PART-17
4	1	Flow Switch	HTR-PART-04
5	1	1-1/2" Pipe Union with "O" Ring	HTR-PART-11 & HTR-PART-15
6	1	Heating Element	Specify kW
7	1	Mounting Feet (One only)	HTR-PART-07
8	1	Hose Adaptor	HTR-PART-12

SEE THE NEXT PAGE FOR PARTS BREAK-OUT DRAWING

Power Requirements

MODEL	KW	VOLTS	PHASE	AMPS
HSS-1.5-115	1.5	115	1	13
HSS-2-115	2	115	1	17.4
HSS-2-220	2	220	1	9
HSS-3-220	3	220	1	13.6
HTI-1.5-115	1.5	115	1	13
HTI-2-115	2	115	1	17.4
HTI-2-220	2	220	1	9
HTI-3-220	3	220	1	13.6
HTI-4-220	4	220	1	18

HSS- 316 STAINLESS STEEL MODELS
HTI- PURE TITANIUM MODELS

Flow Requirements

Your Elecro heater is factory set to accept input water flow entering on the left and exiting on the right, this can be reversed by switching the flow switch and the sensor positions (see diagram below).

Heaters models with **flow switch only**, carefully reverse the switch to allow the water flow to enter in the opposite direction.

Warning!

The flow switch paddle can be damaged if it is NOT removed straight up and out of the housing. When installing flow switch it is important to ensure that it is firmly locked in the correct orientation perpendicular (at a right angle) to the flow of water. Once it is installed DO NOT ROTATE, damage to the paddle could occur.

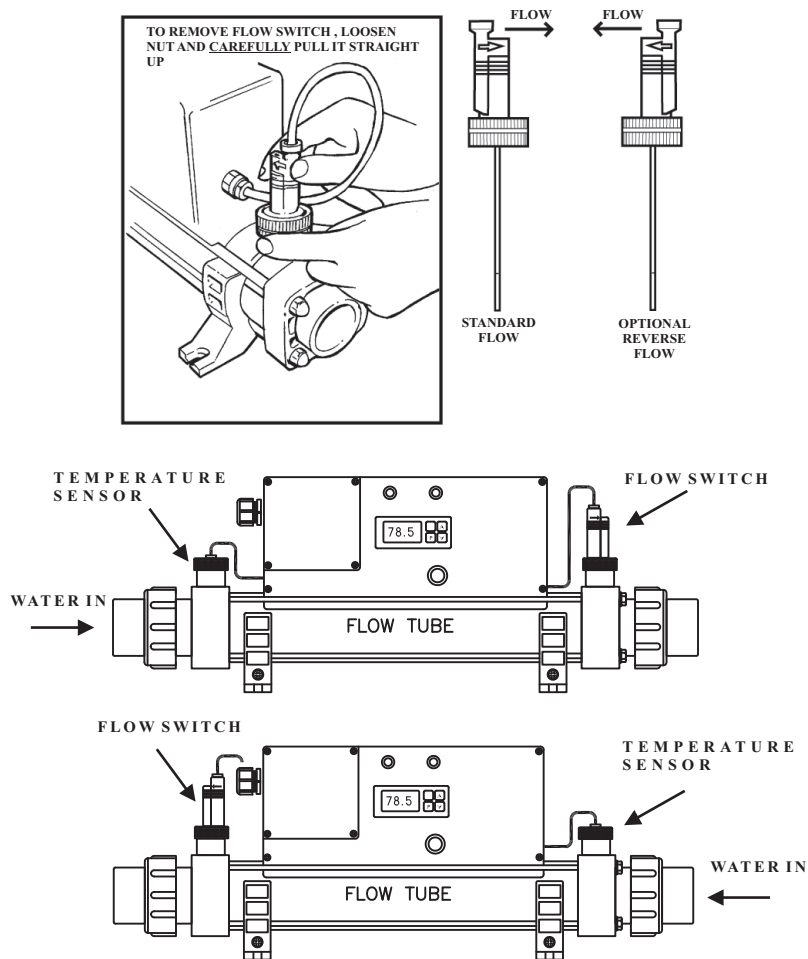

Trouble Shooting Continued

Possible Cause #3

Insufficient Flow

The flow rate through the heater needs to be confirmed to be sufficient. Switch off the circulating pump, close the ball valve unions and carefully un-screw and remove the flow switch. (Use caution as you will experience a small amount of water loss as you un-screw the flow switch and conduct the test). With the heater switched on, manually move the paddle of the flow switch to simulate water flow. If the heater switches on release the paddle **immediately** to ensure the unit doesn't overheat. Carefully reinstall the flow switch and increase the flow rate through the heater. Dirty filters or blockages can cause a significant reduction in flow.

No lights appear on the heater when it is switched on

Possible cause: Power Failure external to the heater - Remedy:

- Check circuit breaker, fuses or other switch components installed in the supply cable.

NOTE: The heater is **not** fitted with a circuit breaker or fuse.

If it becomes necessary to confirm that your Elecro heater is delivering the specified heat output, there are two ways to do so.

1. Have an qualified electrician measure the running amperage of the heater.
2. Take a electrical reading from the property's main electricity meter. Two readings will need to be taken with an exact one hour interval (i.e. take one meter reading then a second reading exactly one hour later). Then by subtracting the first reading from the second reading the number of units (kilo watts / kW) consumed can be calculated. Note that your Elecro heater is also rated in kW hours. To avoid inaccurate results when performing this test, it is important to refrain from using other high current drawing appliances in the property (such as tumble dryer, stoves etc). The water pump and heater will need to be running (i.e. red light on) continuously during the test. A large water pump of 1 horsepower will draw less than 1-kW in a one hour period.

The conclusion of the test should prove that for example a 6-kW heater and a ½ horsepower pump will draw between 6.3-kW to 6.5-kW in one hour. It is impossible for an Elecro heater to waste energy. All the power drawn by the heater will be turned into heat and transferred to the water.

Due to the high efficiency of the Elecro heater no warmth should be detectable from the metal flow tube of the heater.

Trouble Shooting

Heater will not switch from standby (amber light) to on (red light)

In most cases this will be the result of one of the following has not been met.

Possible Cause #1

The set point temperature has been achieved.

To confirm that the digital thermostat is requesting the unit to heat, see if there is an illuminated red dot above the word on the digital thermostat (5 on diagram below). If illuminated go to step 2, if not illuminated raise the set point temperature to a value higher than the current water temperature. Confirm whether the heater now switches to 'Heat On' mode (red light).

5 = If Continuously Illuminated

Indicates that the current water temperature has fallen below the set point temperature.

5 = If Flashing

Indicates that the unit is in time delay mode

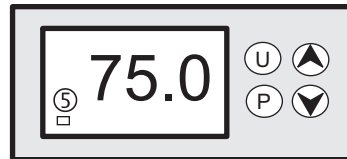

Possible Cause #2

The high limit thermostat has tripped.

Remedy; Remove button cover and press red button to re-set (See pictures below).

If a positive click is felt, the cause of the tripping **must** be investigated and could be caused by a debris build up or air pocket forming inside the flow tube of the heater.

Step 1 - Unscrew the black cover



Step 2 - Push the red button



2 kW thru 4 kW HEATERS

Flow Rate vs. Pressure Drop

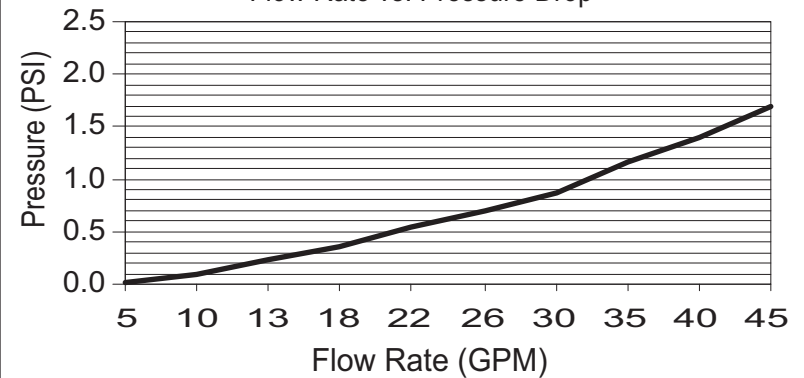

Water Quality

To pro-long the life of the unit, pre-filtration of the water **must** be used to keep the heating element(s) clean.

The water quality must be within the following limits: PH 6.8-8.0

Titanium Aquatic heaters **ARE** suitable for use with salt water.

Stainless steel Aquatic heaters are **NOT** suitable for use with salt water.

The flow rate of water entering the heater **must not** exceed 2640 GPH (10,000 Lts/h). A higher flow rate **will** require the installation of a by-pass to prevent damage to the heating element(s).

The heater will not operate with a flow rate of less than 600 GPH (2,275 Lts/h).

For water flow rate vs. pressure drop see the chart above.

Only clean filtered water should enter the heater.

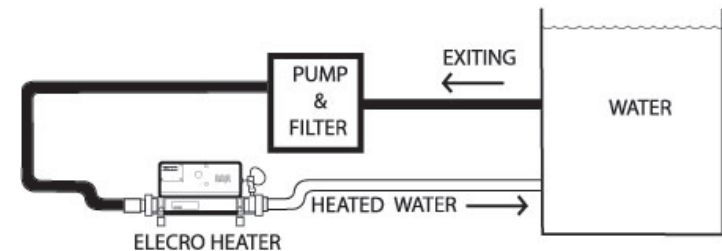

Digital Thermostat Instructions

The digital thermostat fitted to your Elecro Aquatic heater, has been pre-programmed with all the necessary parameters to ensure reliable service & operation. The digital thermostat is pre-set with a temperature range from 0 °F to 104 °F. with a resolution of 1/10 of a degree °F.

All you need to do is set the temperature you would like to maintain in your tank or pond (This is called the set point*).

To display / modify the set point temperature, press and release the P button (see diagram below). The pre-programmed set point temperature will be displayed. Press the up arrow ▲ (3) to increase or the down arrow ▼ (2) to decrease the set point.

Once the desired set point value has been selected, do not touch any of the keys for 5 seconds. The unit will then revert to displaying the current water temperature, but will now control the water temperature to a maximum of the selected set point.

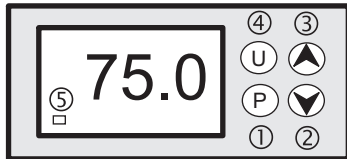

1	P Button	Used to display / modify the set point temperature
2	Down Button	Used to decrease the value
3	Up Button	Used to increase the value
4	Not Used	NOT USED
5	LED - OUT	Indicates that the water temperature has fallen below the set point

***Set Point (Note)** The set point is the maximum temperature that the digital thermostat will allow the water to be heated to. Upon reaching the set point temperature the digital thermostat will switch the heater off, it does not increase or decrease the power output of the heater.

Warning!

When deciding upon the set point temperature, remember that the fish can be traumatised if their environmental temperature is dramatically changed over a short period of time, any changes should be made gradually.

Time Switching Delay

To prevent overheating of the switch components within the heater caused by frequent on and off switching (cycling), the digital thermostat has been pre-programmed with a time delay function. This prevents rapid fluctuations in water temperature from switching the heater on and off more than once in a two minute period.

The time delay mode is indicated by the flashing of red indicator “5” on the digital thermostat (see diagram on prior page).

Differential:

When the water has reached the set point temperature the heater will switch off and will not switch back on until the water temperature has dropped by 1°F. This value is known as the differential and is also in place to prevent overheating to the switch components caused by cycling.

Controller Display Calibration

If the displayed water temperature on the heater is different from the system water temperature, than an adjustment to the heater control can be done. The easiest way to calibrate the control is to first power down the heater, then while pressing and holding the "P" button, power up the heater. The parameter “SPLL” will show on the display. Use the down arrow until you see the menu parameter “OF5”. Press the “P” button one time. The display will show “0”. Press the up or down arrows to adjust to the temperature offset. Once you have set the correct temperature offset, press "P" one time and then wait 15 seconds. The display should read correct water temperature, if not press “P” twice.

To adjust other parameters in the control contact Aqua Logic, Inc. for help. PH: 858.292.4773 email: info@aqualogicinc.com

Operating Your Elecro Heater

Upon completion of the installation, run the water-circulating pump to purge the system & heater of air. On initial power up of the heater, the amber light located on the front face of the heater should be illuminated. Only when the water circulating pump is operational and delivering in excess of 600 GPH of flow (2,275 Lts/h) and the digital thermostat is set to a value higher than that of the water temperature, will the red indicator light turn on and the amber indicator light turn off. In this mode the heater is on and heating.