

# HP-15 & HP-20 SPECIFICATION

FOR INDOOR OR OUTDOOR FRESH AND SALT WATER APPLICATIONS

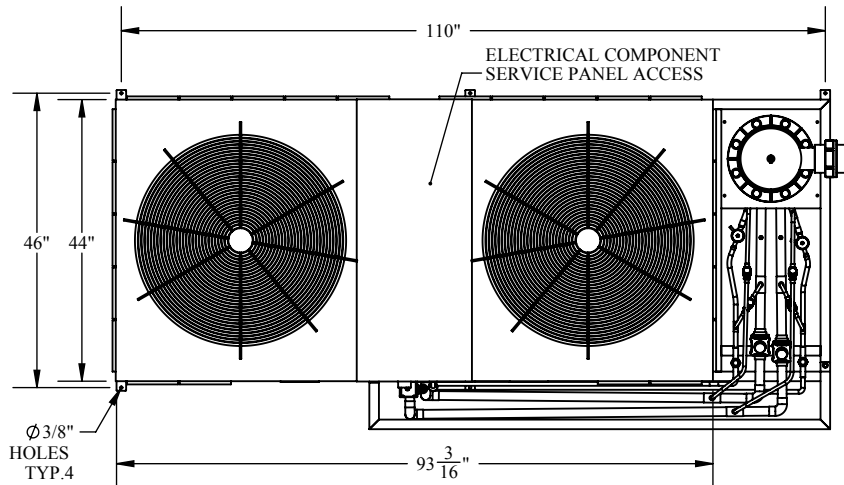

PLAN VIEW

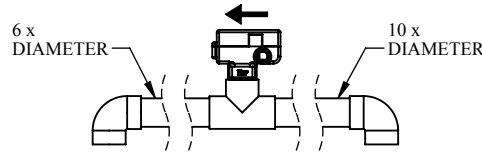

**IMPORTANT!**  
**DETAIL "A"**

· FLOW SWITCH MUST BE FIELD INSTALLED HORIZONTAL WITH NO LESS THAN 10 TIMES THE DIAMETER OF STRAIGHT PIPE ON THE INLET SIDE AND NO LESS THAN 6 TIMES THE DIAMETER ON THE OUTLET SIDE.

**\*NOTES:**

- AIR OUTLET DISCHARGE SHOULD BE UNRESTRICTED AT LEAST 100 INCHES ABOVE THE UNIT.
- UNIT SHOULD BE PLACED SO ROOF RUN-OFF WATER DOES NOT POUR DIRECTLY ON UNIT.
- MINIMUM CLEARANCE FOR PROPER OPERATION IS 36 INCHES FROM WALLS, SHRUBBERY, FENCES, ETC.
- MINIMUM CLEARANCE BETWEEN ADJACENT UNITS IS 72 INCHES.
- ALL DIMENSIONS ARE APPROXIMATE AND CAN CHANGE AT ANY TIME.

**OPTIONS:**

- SCH 80 SHELL CONSTRUCTION.
- 316 STAINLESS STEEL STAND AND HARDWARE.
- LOW AMBIENT HEAD PRESSURE CONTROL (USE IN 50 °F WEATHER AND BELOW).
- HAIL GUARDS TO PROTECT CONDENSER FINS.
- COASTAL MARINE CONDENSER COATING.

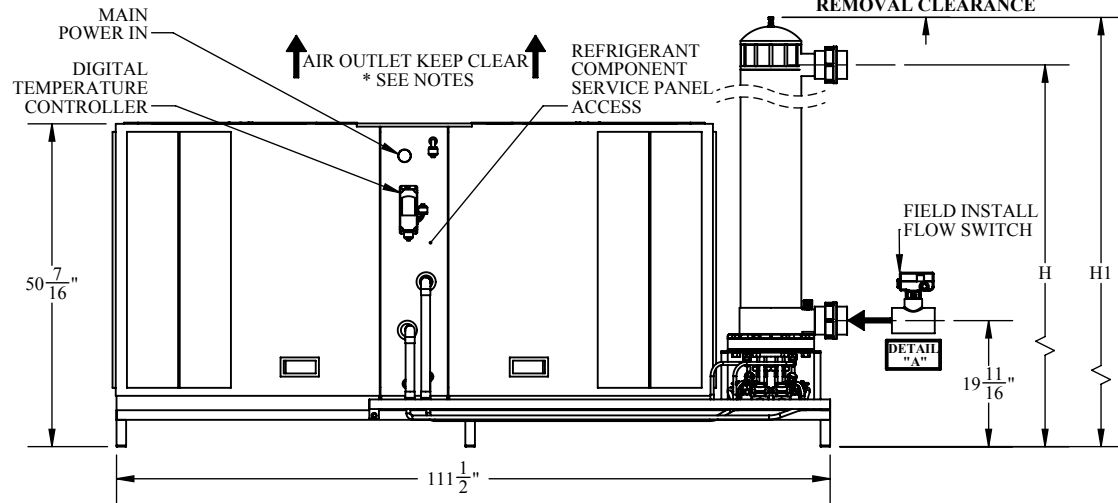

FRONT

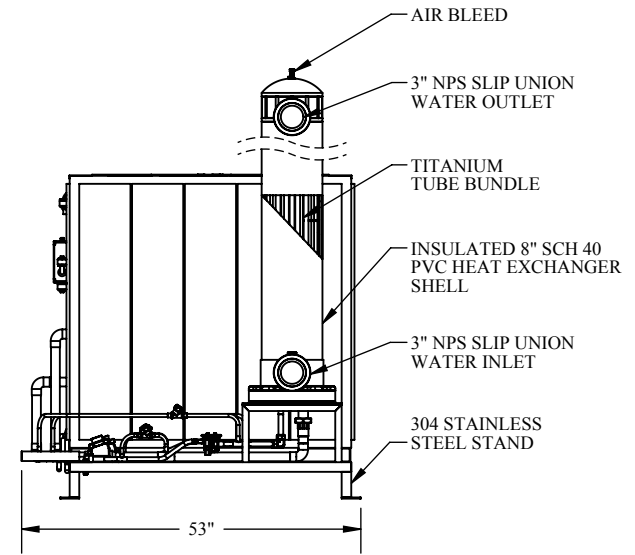

RIGHT

TITAN HEAT PUMP													
MODEL NO.	NOMINAL CAPACITY TONS / BTUH / KW	COP	VOLTS / PHASE	AMPS RLA / LRA	UNIT OPERATING VOLTAGE RANGE	MINIMUM CIRCUIT AMPACITY	MAXIMUM FUSE SIZE OR MAXIMUM CIRCUIT BREAKER (a)	WATER FLOW RATE (GPM)	AIR OULET EA. FAN (CFM)	H1	H	CL SHELL	SHIPPING WEIGHT (-lbs.)
HP-15	15 / 180K / 52.7	3.2	208 - 230 / 3	50 / 164	187 - 253	66.3	80	120 / 180	9750	78"	72 1/2"	63 1/2"	1578
HP-15-460	15 / 180K / 52.7	3.2	460 / 3	25 / 100	414 - 506	33.4	40	120 / 180	9750	78"	72 1/2"	63 1/2"	1578
HP-20	20 / 240K / 70.2	2.9	208 - 230 / 3	78 / 267	187 - 253	98	110	120 / 180	9750	91"	83 1/2"	75 1/2"	1657
HP-20-460	20 / 240K / 70.2	2.9	460 / 3	40 / 142	414 - 506	46.9	60	120 / 180	9750	91"	83 1/2"	75 1/2"	1657

-(a) HACR TYPE CIRCUIT BREAKER PER NEC

\* COPYRIGHT \*  
These drawings including design idea and construction techniques herein are the sole property of Aqua Logic Inc. They shall not be revised, copied, or reproduced in any manner without the written consent of Aqua Logic Inc.

DESCRIPTION  
TITAN HEAT PUMP AIR COOLED

DRAWN BY	DATE	REVISION	SCALE	SHEET #
Arnaldo Guzman	11/13/2015			1 OF 1

DRAWING # PDF-0308 SHEET TITLE



9558 Camino Ruiz, San Diego, CA 92126

HP-15 THRU HP-20 SPECIFICATIONS