

# MT-1 THRU MT-8-WCV WATER COOLED CHILLER

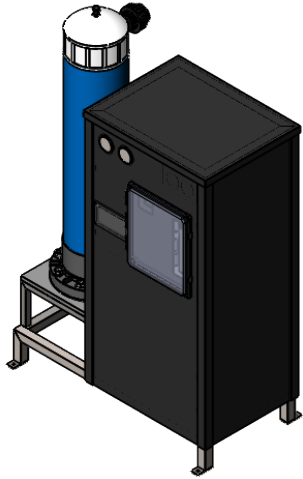

NO.	NAME
1	EVAPORATOR-TITANIUM TUBE / 8" SCH 40 PVC SHELL
2	TEMPERATURE CONTROLLER / NEMA 4X ELECTRICAL CONTROL BOX
3	JUNCTION BOX FOR SUPPLY POWER
4	WATER FLOW SWITCH (SEE NOTE FOR INSTALLATION)
5	2" NPS SLIP UNION EVAPORATOR WATER INLET
6	2" NPS SLIP UNION EVAPORATOR WATER OUTLET
7	LOW / HI REFRIGERANT PRESSURE SAFETY CUTOUT
8	CONDENSER WATER OUTLET
9	CONDENSER WATER INLET
10	CONDENSER WATER CLEAN OUT OUTLET
11	CONDENSER WATER CLEAN OUT INLET
12	REFRIGERANT PRESSURE GAUGES

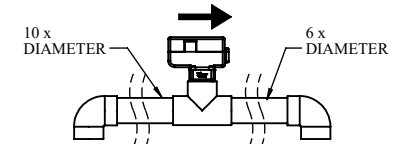
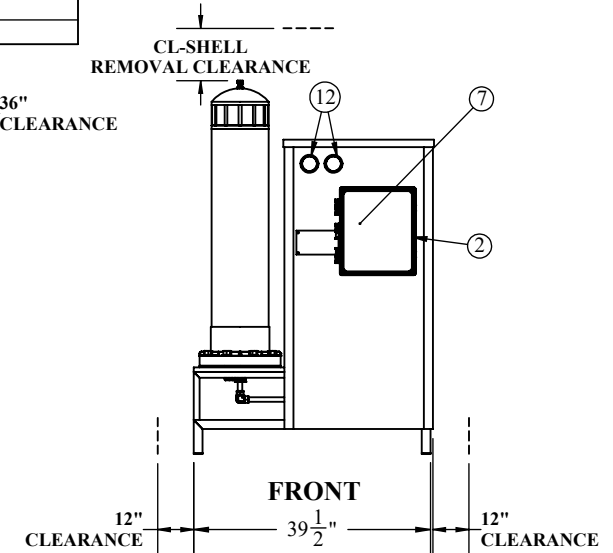
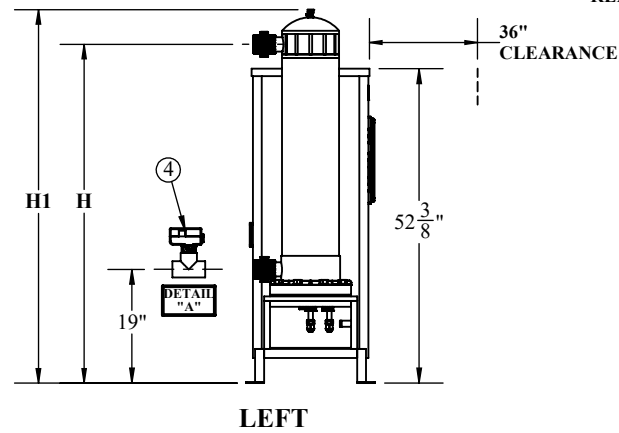
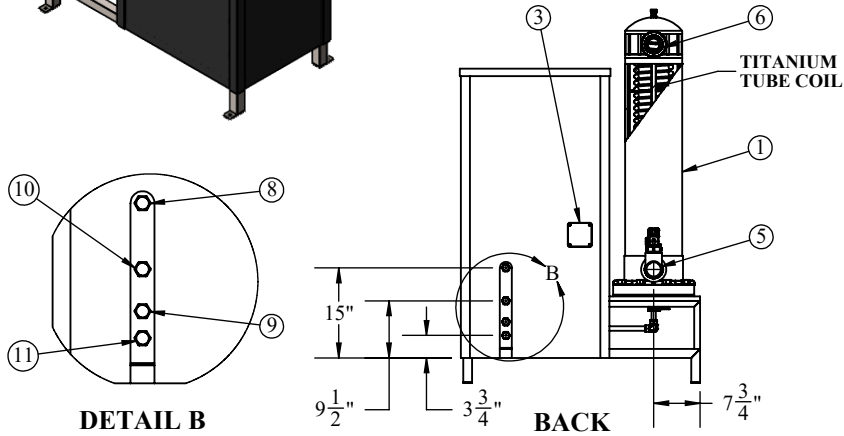
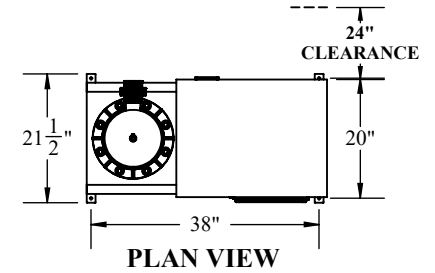

**\*\* IMPORTANT! -DETAIL "A" \*\***  
 -FLOW SWITCH MUST BE FIELD INSTALLED VERTICALLY ON A HORIZONTAL STRAIGHT PIPE WITH NO LESS THAN 10 TIMES THE PIPE DIAMETER ON THE INLET SIDE AND NO LESS THAN 6 TIMES THE DIAMETER ON THE OUTLET SIDE.

MULTI-TEMP WATER-COOLED CHILLERS

MODEL NO.	NOMINAL TON / BTUH	VOLTS / PHASE	R-410A REFRIGERANT CHARGE LBS/OZ	AMPERAGE RLA / LRA	EVAPORATOR WATER FLOW MIN/MAX (GPM)	CONDENSER WATER FLOW MIN/MAX (GPM)	CONDENSER WATER CONNECTION (NFFT)	H	H1	CL	DRY WEIGHT (LBS.)
MT-1-WCV	2 / 24,000	208-240 / 1	3 / 5	13.8 / 127	20 / 40	2 / 4	1/2"	34"	n/a	25"	320
MT-3-WCV	3 / 36,000	208-240 / 1	3 / 10	16.6 / 175	20 / 40	2 / 5	1/2"	41"	n/a	32"	330
MT-4-WCV	3 / 36,000	208-240 / 3	3 / 10	12.7 / 128	20 / 40	2 / 5	1/2"	41"	n/a	32"	330
MT-4-460-WCV	3 / 36,000	460 / 3	3 / 10	7.5 / 63	20 / 40	2 / 5	1/2"	41"	n/a	32"	330
MT-5-WCV	4 / 48,000	208-240 / 1	4 / 12	17.3 / 129	30 / 60	3 / 7	3/4"	49"	54 7/8"	39"	350
MT-6-WCV	4 / 48,000	208-240 / 3	4 / 12	13 / 156	30 / 60	3 / 7	3/4"	49"	54 7/8"	39"	350
MT-6-460-WCV	4 / 48,000	460 / 3	4 / 12	8 / 75	30 / 60	3 / 7	3/4"	49"	54 7/8"	39"	350
MT-7-WCV	5 / 60,000	208-240 / 1	7 / 5	23 / 129	30 / 60	4 / 8	3/4"	56 1/2"	62 3/8"	47"	360
MT-8-WCV	5 / 60,000	208-240 / 3	7 / 5	19.3 / 225	30 / 60	4 / 8	3/4"	56 1/2"	62 3/8"	47"	360
MT-8-460-WCV	5 / 60,000	460 / 3	7 / 5	9.8 / 114	30 / 60	4 / 8	3/4"	56 1/2"	62 3/8"	47"	360

**OPTIONS:**

- SCH 80 PVC SHELL CONSTRUCTION.
- 316 STAINLESS STEEL STAND AND HEX BOLTS.

**NOTES:**

- WHEN THE CHILLER IS IN THE OFF CYCLE, WATER FLOWING THROUGH THE CONDENSER IS STOPPED.
- WATER FLOW RATE THROUGH THE EVAPORATOR NEEDS TO BE AT THE MAXIMUM FLOW RATE WHEN WATER TEMPERATURE IS 55°F AND BELOW.
- ALL UNITS ARE 60 HZ.
- CONDENSER FLOW RATE IS BASED ON A MINIMUM OF 55°F AND MAXIMUM OF 75°F WATER TEMPERATURE. IF OPERATING OUTSIDE THESE PARAMETERS CONTACT AQUA LOGIC TECHNICAL SUPPORT.
- ALL DIMENSIONS ARE APPROXIMATE AND CAN CHANGE AT ANY TIME.



9558 Camino Ruiz, San Diego, CA 92126

DRAWING # PDF-0230

SHEET TITLE

MT-1 THRU MT-8-WCV SPECIFICATIONS

BALLON LEGEND  
 ITEM NO. QTY.

\* COPYRIGHT \*  
 These drawings including design idea and construction techniques herein are the sole property of Aqua Logic Inc. They shall not be revised, copied, or reproduced in any manner without the written consent of Aqua Logic Inc..

DESCRIPTION

MT-1 THRU MT-8-WCV WATER COOLED CHILLER.

DRAWN BY

DATE

REVISION

3/24/2022

SCALE

SHEET #

1 OF 1