

MT-1 THRU MT-8 SPECIFICATION

FOR INDOOR OR OUTDOOR FRESH AND SALT WATER APPLICATIONS

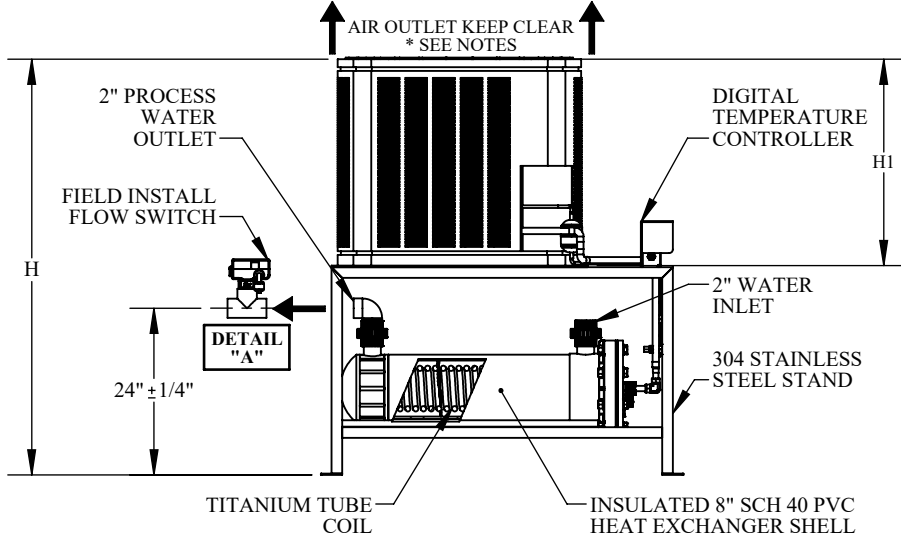

FRONT VIEW

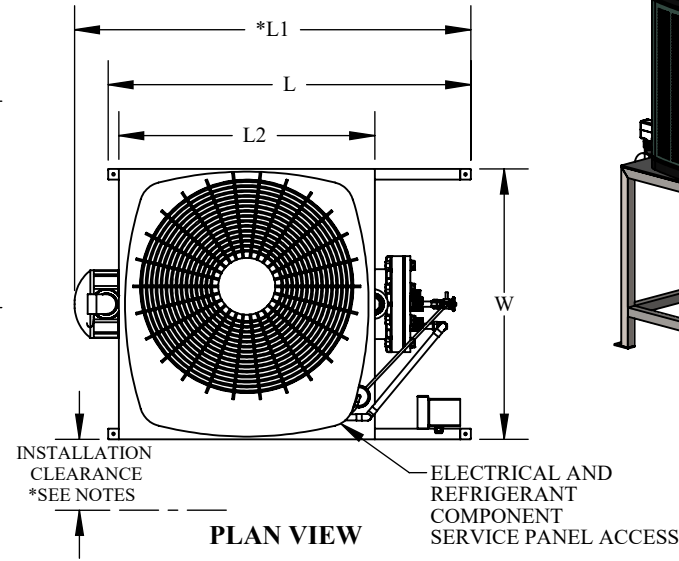

PLAN VIEW

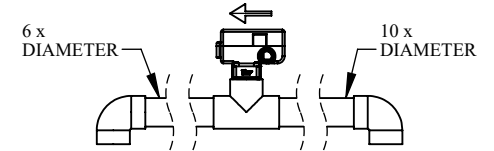
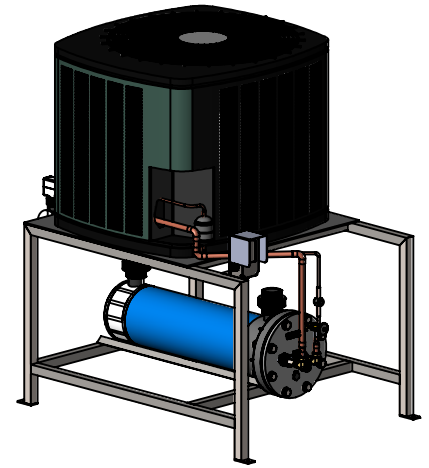

IMPORTANT!
DETAIL "A"

· FLOW SWITCH MUST BE FIELD INSTALLED HORIZONTALLY WITH NO LESS THAN 10 TIMES THE DIAMETER OF STRAIGHT PIPE ON THE INLET SIDE AND NO LESS THAN 6 TIMES THE DIAMETER ON THE OUTLET SIDE.

OPTIONS:

- SCH 80 SHELL CONSTRUCTION.
- 316 STAINLESS STEEL STAND AND HARDWARE.
- LOW AMBIENT HEAD PRESSURE CONTROL.
- COASTAL MARINE CONDENSER COATING.

MULTI-TEMP WATER CHILLERS												
MODEL NO.	NOMINAL TONS / BTUH / KW	VOLTS / PHASE	AMPS RLA / LRA	WATER FLOW RATE (GPM)	*AIR OUTLET (CFM)	H	H1	L	*L1	L2	W	SHIPPING WEIGHT (lbs.)
MT-1	2 / 24K / 7	208 - 240 / 1	11 / 63	20 / 40	1285	59"	29"	44"	n/a	31"	33"	370
MT-3	3 / 36K / 10.5	208 - 240 / 1	18 / 77	20 / 40	2615	63"	33"	44"	n/a	31"	33"	396
MT-4	3 / 36K / 10.5	208 - 240 / 3	10 / 71	20 / 40	2615	66"	37"	44"	n/a	31"	33"	386
MT-4-460	3 / 36K / 10.5	460 / 3	6 / 38	20 / 40	2615	66"	37"	44"	n/a	31"	33"	386
MT-5	4 / 48K / 14	208 - 240 / 1	23 / 124	30 / 60	2615	59"	29"	51"	n/a	36"	38"	474
MT-6	4 / 48K / 14	208 - 240 / 3	15 / 83	30 / 60	2615	63"	33"	51"	n/a	36"	38"	474
MT-6-460	4 / 48K / 14	460 / 3	7 / 41	30 / 60	2615	63"	33"	51"	n/a	36"	38"	474
MT-7	5 / 60K / 17.5	208 - 240 / 1	27 / 153	30 / 60	2785	70"	41"	51"	56"	36"	38"	520
MT-8	5 / 60K / 17.5	208 - 240 / 3	17 / 110	30 / 60	2785	70"	41"	51"	56"	36"	38"	528
MT-8-460	5 / 60K / 17.5	460 / 3	8 / 52	30 / 60	2785	70"	41"	51"	56"	36"	38"	500

*NORMAL OPERATING AMBIENT AIR TEMPERATURE: 50°F - 115°F.

*ADD LOW AMBIENT HEAD PRESSURE CONTROL FOR OPERATING IN AMBIENT AIR TEMPERATURES FROM 0°F TO 50°F. CONSULT AQUA LOGIC IF OPERATING AT TEMPERATURES OUTSIDE THESE RANGES.

*ALL CONDENSING UNITS HAVE A 13 SEER RATING.

*L1 DIMENSION ARE FOR MODELS MT-7 & MT-8 CHILLERS.

***NOTES:**

- TOP DISCHARGE AREA SHOULD BE UNRESTRICTED FOR 60 INCHES MINIMUM.
- UNIT SHOULD BE PLACED SO ROOF RUN-OFF WATER DOES NOT POUR DIRECTLY ON UNIT.
- MINIMUM CLEARANCE FOR PROPER OPERATION IS 12 INCHES FROM WALLS, SHRUBBERY, FENCES, ETC.
- MINIMUM CLEARANCE BETWEEN ADJACENT UNITS IS 72 INCHES.
- ALL DIMENSIONS ARE APPROXIMATE AND CAN CHANGE AT ANY TIME.

* COPYRIGHT *
These drawings including design idea and construction techniques herein are the sole property of Aqua Logic Inc. They shall not be revised, copied, or reproduced in any manner without the written consent of Aqua Logic Inc.

DESCRIPTION
MULTI TEMP AIR COOLED WATER CHILLER

DRAWN BY
Arnaldo Guzman

DATE
9/10/2021

REVISION

SCALE
1:27

SHEET #
1 OF 1

DRAWING #
PDF-0052

SHEET TITLE

MT-1 THRU MT-8 SPECIFICATIONS

9558 Camino Ruiz, San Diego, CA 92126

