

MT-15 & MT-20 SPECIFICATION

FOR INDOOR OR OUTDOOR FRESH AND SALT WATER APPLICATIONS

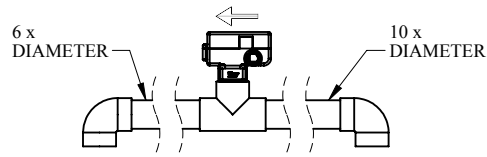
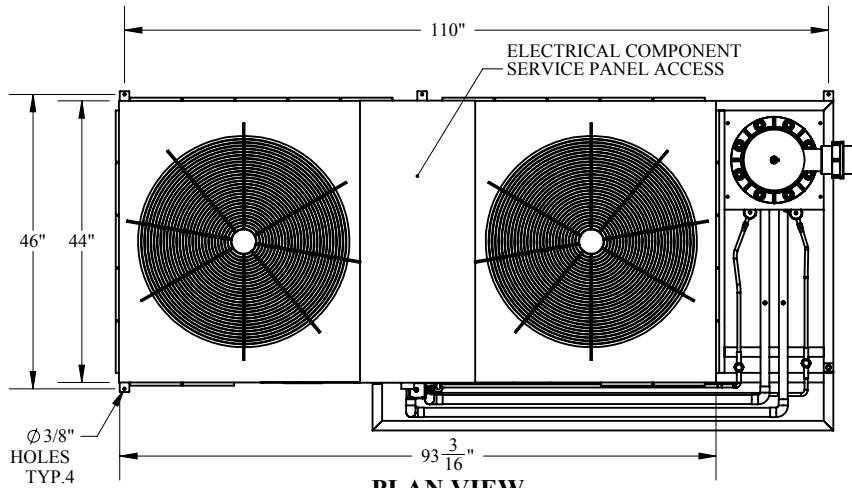

IMPORTANT!
DETAIL "A"

· FLOW SWITCH MUST BE FIELD INSTALLED HORIZONTAL WITH NO LESS THAN 10 TIMES THE DIAMETER OF STRAIGHT PIPE ON THE INLET SIDE AND NO LESS THAN 6 TIMES THE DIAMETER ON THE OUTLET SIDE.

***NOTES:**

- AIR OUTLET DISCHARGE SHOULD BE UNRESTRICTED AT LEAST 100 INCHES ABOVE THE UNIT.
- UNIT SHOULD BE PLACED SO ROOF RUN-OFF WATER DOES NOT POUR DIRECTLY ON UNIT.
- MINIMUM CLEARANCE FOR PROPER OPERATION IS 36 INCHES FROM WALLS, SHRUBBERY, FENCES, ETC.
- MINIMUM CLEARANCE BETWEEN ADJACENT UNITS IS 72 INCHES.
- ALL DIMENSIONS ARE APPROXIMATE AND CAN CHANGE AT ANY TIME.

OPTIONS:

- SCH 80 SHELL CONSTRUCTION.
- 316 STAINLESS STEEL STAND AND HARDWARE.
- LOW AMBIENT HEAD PRESSURE CONTROL (USE IN 50 °F WEATHER AND BELOW).
- HAIL GUARDS TO PROTECT CONDENSER FINS.
- COASTAL MARINE CONDENSER COATING.

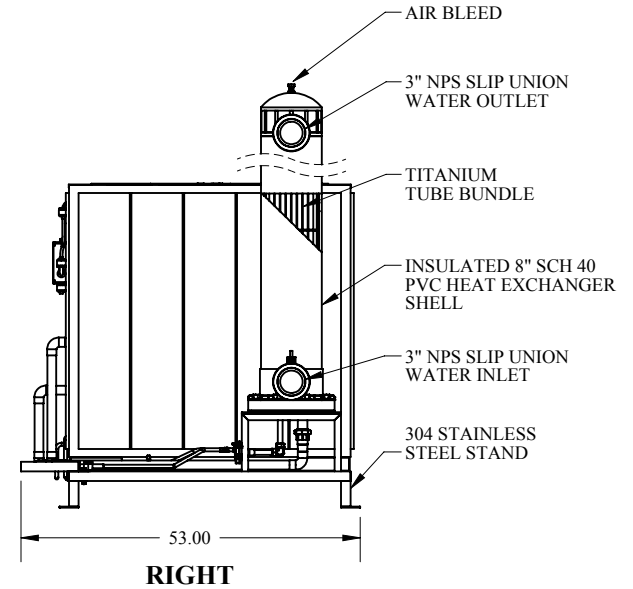
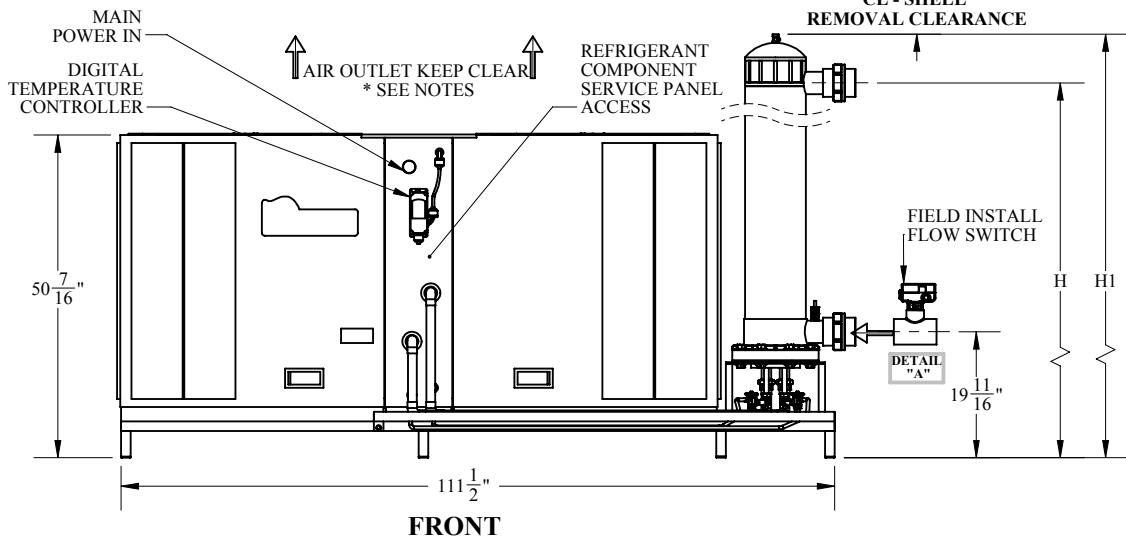

MULTI-TEMP WATER CHILLERS												
MODEL NO.	NOMINAL CAPACITY TONS / BTUH / KW	VOLTS / PHASE	AMPS RLA / LRA	UNIT OPERATING VOLTAGE RANGE	MINIMUM CIRCUIT AMPACITY	MAXIMUM FUSE SIZE OR MAXIMUM CIRCUIT BREAKER (a)	WATER FLOW RATE (GPM)	AIR OULET EA. FAN (CFM)	H1	H	CL SHELL	SHIPPING WEIGHT (-lbs.)
MT-15	15 / 180K / 52.7	208 - 240 / 3	50 / 164	187 - 253	66.3	80	120 / 180	9750	78"	72 1/2"	63 1/2"	1559
MT-15-460	15 / 180K / 52.7	460 / 3	25 / 100	414 - 506	33.4	40	120 / 180	9750	78"	72 1/2"	63 1/2"	1559
MT-20	20 / 240K / 70.2	208 - 240 / 3	78 / 267	187 - 253	98	110	120 / 180	9750	91"	83 1/2"	75 1/2"	1714
MT-20-460	20 / 240K / 70.2	460 / 3	40 / 142	414 - 506	46.9	60	120 / 180	9750	91"	83 1/2"	75 1/2"	1714

-(a) HACR TYPE CIRCUIT BREAKER PER NEC

* COPYRIGHT *
These drawings including design idea and construction techniques herein are the sole property of Aqua Logic Inc. They shall not be revised, copied, or reproduced in any manner without the written consent of Aqua Logic Inc.

DESCRIPTION
MULTI TEMP AIR COOLED WATER CHILLER

DRAWN BY
Arnaldo Guzman

DATE
2/1/2018

REVISION

SCALE
1:30

SHEET #
1 OF 1

DRAWING #
PDF-0305

SHEET TITLE

MT-15 & MT-20 SPECIFICATIONS

9558 Camino Ruiz, San Diego, CA 92126

