

TOP DISCHARGE AREA SHOULD BE UNRESTRICTED FOR 100 INCHES MINIMUM. UNIT SHOULD BE PLACED SO ROOF RUN-OFF WATER DOES NOT POUR DIRECTLY ON UNIT.

KEEP CLEAR AIR OUTLET

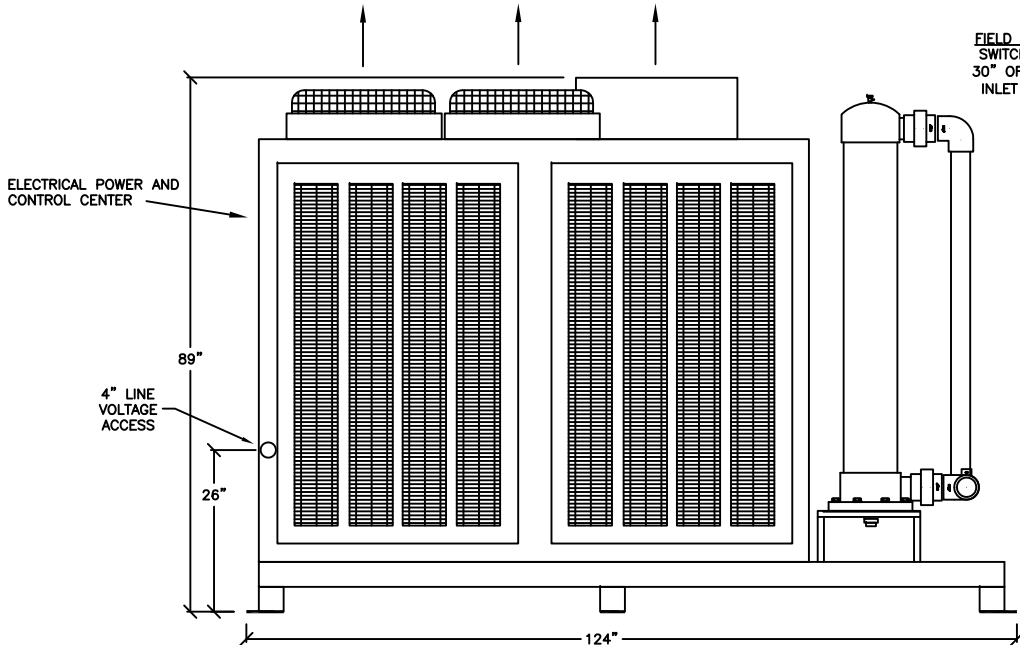

SIDE VIEW

FIELD INSTALLED FLOW SWITCH SWITCH MUST HAVE AT LEAST 30" OF STRAIGHT PIPE ON THE INLET AND AT LEAST 18" ON THE OUTLET

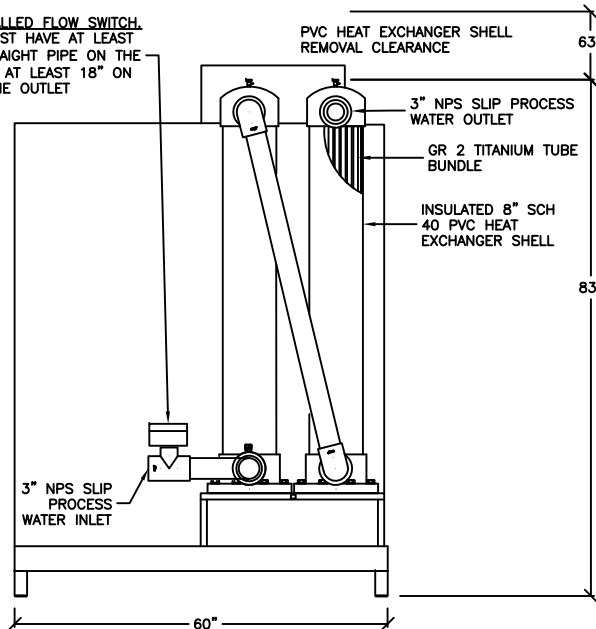

FRONT VIEW

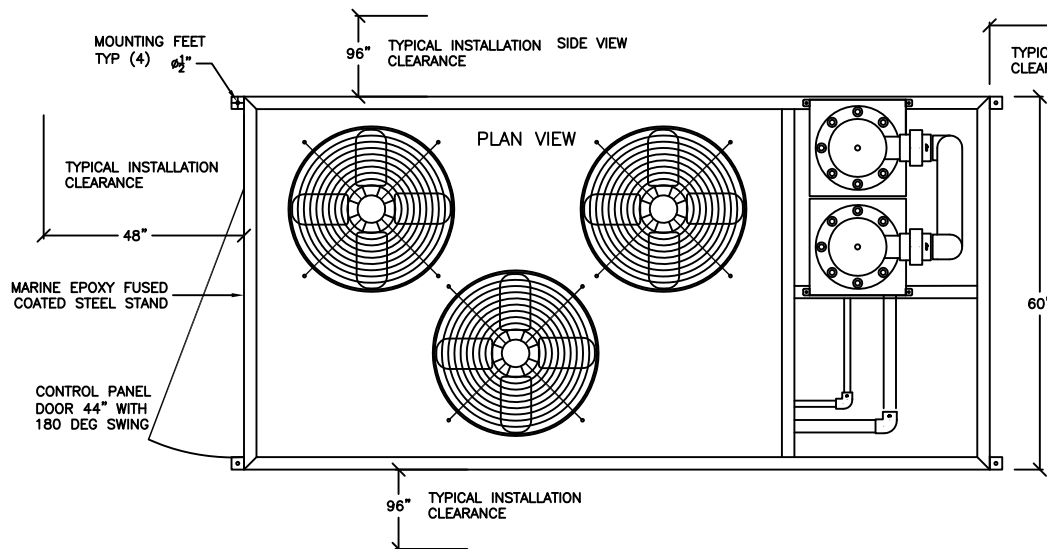

PLAN VIEW

SPECIFICATIONS:

MODEL NO:	MT-30 460
TONS:	30
VOLTS / PH / Hz	460 / 3 / 60
VOLTAGE MIN-MAX	414 - 506
TOTAL UNIT AMPS	54 RLA 195 LRA
MIN. CIRCUIT AMPS.	65
RECOMMENDED DUAL ELEMENT FUSE SIZE	70
MAX. OVERLOAD PROTECTION DEVICE	80
NET CAPACITY (MBH)	376,000
MIN - MAX WATER FLOW	120 / 160 GPM
TOTAL FANS CFM	20,900
SHIPPING WEIGHT	2500 LBS
REFRIGERANT TYPE	R-410A (25 LBS.)
STANDARD AMBIENT OPERATING RANGE	40-115 F
LOW AMBIENT OPTION	0 F
EER RATING	11.3

 <small>Aquatic Design, Manufacturing & Integration</small>	AQUA LOGIC, INC. 9558 CAMINO RUIZ, SAN DIEGO, CA 92126
	TITLE: MT-30 460V 3Ø R-410a