

AQUA LOGIC'S **MULTI-TEMP® and TITAN Series chiller and heat pumps**
MT- 9 thru MT- 20 and HP- 6 thru HP- 20

INSTALLATION & OPERATING INSTRUCTIONS

Effective 1-2016

Thank you for purchasing an Aqua logic chiller and or heat pump. It has been designed and built to provide years of reliable, trouble-free service. It provides a precise water temperature control up to +/- 1.0°F (0.7°C) accuracy and features a continuous LCD display of the current fluid temperature.



BEFORE INSTALLING THE CHILLER
READ BOTH WARRANTY AND INSTALLATION INSTRUCTIONS.

Important: Unpacking your chiller or heat pump

This chiller was properly packed and accepted by the transportation company for shipment. It is the responsibility of the transportation company to deliver it to you in perfect condition.

APPARENT DAMAGE OR LOSS

If, upon delivery, the shipping container or equipment indicates DAMAGE IN TRANSIT, such damaged goods should not be accepted until the transportation company's agent has noted on the freight bill, which he will give you, the nature and extent of the damage. If any part of this shipment is LOST IN TRANSIT, have the shortage noted on the freight bill by the agent.

CONCEALED DAMAGE

If, when this equipment is unpacked, shipping damage is discovered which was not apparent upon delivery, notify the transportation company IMMEDIATELY to inspect the damaged equipment. The inspector is REQUIRED to provide you with a DAMAGE INSPECTION report.

THIS INSPECTION MUST BE REQUESTED WITHIN FIFTEEN (15) DAYS OF DELIVERY. DO NOT MOVE DAMAGED SHIPMENTS FROM POINT OF DELIVERY. RETAIN ALL CONTAINERS AND PACKING FOR INSPECTION.

Protect yourself. File your claim immediately with the transportation company! Remember, Aqua Logic Inc. is not responsible for any damage after the carrier accepts a shipment. Claim for FULL VALUE REIMBURSEMENT should be made by you against the transportation company. Replacement of the damaged equipment should be requested by the purchaser as a new order.

WARNING!!!

**THIS DEVICE USES HIGH VOLTAGE ELECTRICAL POWER FOR OPERATION.
SAFETY PRECAUTIONS MUST BE OBSERVED.
CAREFULLY READ AND OBSERVE THE FOLLOWING TO AVOID ELECTRICAL SHOCK
OR SEVERE DAMAGE TO THE EQUIPMENT.**

- We recommend, as with all electrical equipment used in or around water, that you connect your electrical equipment to a ground-fault interrupt (GFI) protection circuit.
- **ALWAYS** turn the power off for the equipment at the source (circuit breaker) if there is any electrical problem, the electrical equipment or controller has been submerged in water.
- **ALWAYS** make sure that the electrical circuit you connect your electrical equipment to is rated at least 20% higher than the maximum current rating on the equipment.
- **ALWAYS** make sure that you operate the equipment at the correct voltage.
- Do **NOT** attempt to turn off the power at the chiller or controller if a problem occurs. Disconnect unit at the main power panel.
Do **NOT** attempt to repair equipment. Call Aqua Logic for instructions.

Very Important!

1. Allow only qualified licensed personnel to supply electric power to chiller or heat pump. Installation must be done in accordance with local and national electrical code. Multi-Temp Chillers and Titan heat pumps need a fusible disconnect installed within five feet. The chiller or heat pump needs a dedicated power supply. **Do not** share the power feed to with any other peripheral devices such as pumps, ultraviolet light sterilizers, or filters. Interlock device prevents the chiller from energizing without the pump being on.
2. Double check electrical specifications on unit's electrical access cover plate making sure of voltage, amperage, phase, and cps before energizing. (**Do not** remove any covers with electrical power on.)
3. Some control packages include condenser fan cycling, and timed switches that delay certain functions on initial start-up. Consult Aqua Logic Inc. for exact details before attempting servicing.
4. **Fluid must flow through the chiller or heat pump at all times.** See specification sheet for minimum and maximum flow rates. Flow rates less than specification may result in evaporator freeze up and cracking PVC plastic evaporator shells. Aqua Logic Inc. does not warranty evaporator shells operating under low flow conditions.
5. Incoming water pressure to the inlet of the evaporator must not exceed 40 psi. Pressures over 40 psi may cause damage to the evaporator shells not covered under warranty.

Installation Instructions:

Installation must proceed in accordance with national building and electrical codes by qualified technicians only.

The chiller or heat pump you have purchased uses Trane condensing units. Consult specification labels on condensing unit for particular details concerning electronic parts, electrical wiring, voltages, amperage, cps, and refrigerant type. These labels are on the backs of covers that require removal to view.

1. Place the chiller or heat pump in a well ventilated area with the condenser fins pointing toward prevailing winds, or source of fresh air intake. Ambient air temperature must never exceed 110° sustained.
2. Aqua Logic Inc. recommends the chiller be mounted outdoors with a protective cover. Outdoor covers must be built allowing ample air flow on five sides.
3. If the chiller is to be located in a building, we recommend providing a source of fresh air such as a hole in an outside wall the size of the condenser fins. Position heat pump within 4' of the air source. Duct and seal condenser fins to outside air if possible.
4. If the chiller must be inside a building without access to outside air, locate unit at least 3' from any single wall and 4' to 6' from any adjacent wall. Locate in such a way as to prevent air recycling. Recycled air may not provide condenser with adequate heat exchange.
5. The evaporator located under the condensing unit, has 2" PVC slip connections on both inlet and outlet. Make sure that inlet and outlet flow is followed if designated.

Safety Precautions

1. Always wear safety eye wear and work gloves when installing equipment.
2. Never assume electrical power is disconnected. Disconnect and check with meter.
3. Keep hands out of fan areas when power is connected to equipment.
4. R-410a escaping into the air can cause frost-bite burns.
5. R-410a is toxic when burned.

Very Important!

1. Before making power available to the chiller, check to see if all fan blades can spin freely. Shipping may have caused fan blades to not turn freely. If this is the case, do not apply power until repaired!
2. Fluid must flow through the chiller or heat pump at all times. See specifications sheet for minimum and maximum flow rates. Flow rates under specifications may result in evaporator freeze up and cracking PVC plastic evaporator shells.
3. Double check specifications on condensing unit making sure of voltage, amperage, phase, and hertz before energizing.
4. Some control packages include condenser fan cycling, and timed switches that delay certain functions on initial start-up. Please consult Aqua Logic Inc. if necessary for exact details of your particular unit.

Initial Start-up: Read all of the instructions before energizing unit.

Caution: It's important to allow the oil in the compressor(s) to warm-up at least 8 hours before starting up the unit. If the ambient air temperature is below 60°F, apply power to the unit and set controller so the compressor(s) do not energize or by-pass the heat exchanger water supply so the flow switch will not activate the unit.

Adjust temperature set point to desired water temperature. When the thermostat calls for cooling, a delay timer will start the system after 3 minutes. The chiller will pull the water temperature down to the set point, and shut the unit down. When the water temperature rises above the differential setting, the chiller will repeat the delay cycle and cool down to temperature set point.

Very Important!

1. Target fluid temperature is limited to a range of 40° F to 80° F on all standard MultiTemp Chillers. Without special factory installed equipment, possible damage to the unit can occur when attempting to access fluid temperatures outside this range. Aqua Logic, Inc.'s warranty does not apply to application temperatures under 40°F or above 80° F without special factory modifications.
2. Water going to the chiller should be protected by filters to keep debris from collecting in the evaporator shells. Clogged shells lead to heat exchange problems and will void the warranty.
3. Improperly installed or out of adjustment rapid sand filters or fluidized beds can put sand into the stream of water flowing into the chiller. This condition is similar to “sand blasting” and may abrade holes in plumbing lines or the titanium coils. Conditions like these would void the Aqua Logic, Inc. warranty.

40° F to 80° F Fluid Temperature Applications

Wetted parts contain titanium, PVC plastic, rubber, and polymer. These materials are non-reactive with fresh and salt water. You must consult with Aqua Logic, Inc. if any other fluids are to be pumped through the chiller.

If humid or wet conditions exist where chiller is to be located, care must be taken to prevent water from getting on electrical components. Fins on condensing unit are made from aluminum and are subject to rapid corrosion, especially near sea water. Fins are thin to aid in heat exchange. Bent fins reduce efficiency and just brushing up against them can bend them over. Heat pumps should be located away from high traffic areas.

The chiller operates by virtue of a thermostat that senses water temperature inside the probe well. When the temperature set point is satisfied, the supply of refrigerant to the evaporator is stopped. This initiates a pump down, and the compressor shuts off. When the thermostat calls for cooling, the supply of refrigerant is re-established to the evaporator, but the system has a time delay of approximately 3 or 5 minutes before the compressor goes on again.

Chiller Control Set-up

<u>Step</u>	<u>Enunciator</u>	<u>Description</u>	<u>Display</u>
1	F or C	Fahrenheit or Celsius	F
2	S1 (Blinking)	Setpoint Temperature	S1 77
3	DIF (Blinking)	Differential Temperature	DIF 1
4	C1 or H1	Cooling or Heating Mode	C1



Liquid Crystal Display (LCD)

The LCD display provides a constant readout of the sensor temperature and indicates if the output relay is energized. When the **S1** enunciator is constantly illuminated during operation, the relay is energized. The display is also used in conjunction with the keypad to allow the user to adjust the set point temperature, differential and heating /cooling modes.

Programming Steps and Display

The control can be programmed in four simple steps using the LCD display and the three keys on the face of the control. (See photo for display and keys.)

1. To start programming, press the **SET** key once to access the Fahrenheit/Celsius mode. The display will show the current status, either **F** for degrees Fahrenheit or **C** for degrees Celsius. Then press either the up ↑ arrow or down ↓ arrow key to toggle between the **F** or **C** designation.
2. Press the **SET** key again to access the set point temperature. The LCD will display the current set point temperature and the set point enunciator will be blinking on and off to indicate that the control is in the set point mode. Then press either the up ↑ key to increase or down ↓ key to decrease the set point to the desired temperature.
3. Press the **SET** key again to access the differential. The LCD will display the current differential and the **DIF** enunciator will be blinking on and off to indicate that the control is in the differential mode. Then press either up ↑ key to increase or the down ↓ key to decrease the differential to the desired setting (minimum 1°F, maximum 30°F).
4. Press the **SET** key again to access the heating mode. The LCD will display the current mode, **C1** for chiller mode and **H1** is for heater mode. Press the **SET** key once more and programming is complete. Controller **MUST** in the **C1** mode for correct operation.

Controller will automatically drop out of “program mode” and return to “operating mode” 30 seconds after last key press.

Troubleshooting Controller Error Messages:

Display Messages

E1 - Appears when the up ↑ or down ↓ key is pressed when not in the programming mode.

To correct: If the E1 message appears even when no keys are being pressed, replace the control.

E2 - Appears if the control settings are not properly stored in memory.

To correct: Check all settings and correct if necessary.

EP - Appears when the probe and or flow switch is open , shorted or sensing a temperature that is out of range.

To correct: Check to see if the sensed temperature is out of range. If not , check for probe damage by comparing it to a known ambient temperature between -30°F and 220°F. Replace the probe is necessary. Also check for proper water flow through heater. If water flow is correct, flow switch.

EE - Appears if the EEPROM data has been corrupted.

To correct: This condition cannot be field repaired. Replace the control.

CL - Appears if calibration mode has been entered.

To correct: Remove power to the control for least five seconds. Reapply power. If the **CL** message still appears, replace the control.

Heat Pump Control Set-up

STEP	ANNUNCIATOR	DESCRIPTION	DISPLAY
1	<i>F or C</i>	Fahrenheit or Celsius Scale	F
2	S1 (blinking)	Stage 1 Setpoint Temperature	77 S1
3	DIF1 (blinking)	Stage 1 Differential Temperature	DIF1 1
4	C1/H1	Stage 1 Heating Mode	H1
5	S2 (blinking)	Stage 2 Setpoint Temperature	77 S2
6	DIF2 (blinking)	Stage 2 Differential Temperature	DIF2 1
7	C2/H2	Stage 2 Cooling Mode	C2



Liquid Crystal Display (LCD)

The LCD display provides a constant readout of the sensor temperature and indicates if the output relay is energized. When the **S1** or **S2** annunciator is constantly illuminated during operation, the relay is energized. The display is also used in conjunction with the keypad to allow the user to adjust the setpoint temperature, differential and heating /cooling modes.

Programming Steps and Display

The control can be programmed in four simple steps using the LCD display and the three keys on the face of the control. (See photo for display and keys.)

NOTE: Stage 1 must be set for heat mode and Stage 2 for cool mode for correct operation.

- To start programming, press the **SET** key once to access the Fahrenheit/Celsius mode. The display will show the current status, either **F** for degrees Fahrenheit or **C** for degrees Celsius. Then press either the up ↑ arrow or down ↓ arrow key to toggle between the **F** or **C** designation.
- Press the **SET** key again to access the heat mode setpoint temperature. The LCD will display the current setpoint temperature and the **S1** annunciator will be blinking to indicate that the control is in the setpoint mode. Press either the up ↑ key to increase or down ↓ key to decrease the setpoint to the desired temperature.
- Press the **SET** key again to access the heat mode differential temperature. The LCD will display the current differential and the **DIF 1** annunciator will be blinking to indicate that the control is in the differential mode. Then press either up ↑ key to increase or the down ↓ key to decrease the differential to the desired setting (minimum 1°F, maximum 30°F).
- Press the **SET** key again to select heat mode. The LCD will display the current mode: **C1** or **H1**. Then press either up ↑ key to increase or the down ↓ key to select the correct Stage 1 mode. Stage 1 **MUST** be in the **H1** mode for correct operation.
- Press the **SET** key again to access the chill mode setpoint temperature. The LCD will display the current chill setpoint temperature and the **S2** annunciator will be blinking to indicate that the control is in the setpoint mode. Then press either the up ↑ key to increase or down ↓ key to decrease the setpoint to the desired temperature. **S1** and **S2** should both be set for the same temperature.
- Press the **SET** key again to access the chill mode differential temperature. The LCD will display the current differential and the **DIF 2** annunciator will be blinking to indicate that the control is in the differential mode. Then press either up ↑ key to increase or the down ↓ key to decrease the differential to the desired setting (minimum 1°F, maximum 30°F). **DIF1** and **DIF2** should both be set to the same value for best results.
- Press the **SET** key again to access the heating mode. The LCD will display the current mode: **C2** or **H2**. Stage 2 **MUST** be in the **C2** mode for correct operation.
- Press the **SET** key again to exit programming mode. Controller will display current water temperature.

Controller will automatically drop out of “program mode” and return to “operating mode” 30 seconds after last key press.

Chiller / Heat Pump Maintenance

Heat Exchanger Cleaning:

The heat exchanger should be cleaned approximately every 12 months or as needed to allow proper performance. On some models this process may be done without removal of the heat exchanger shell. (i.e., water flushing system)

WARNING:

When using bleach and acid special care should be observed.
Always wear hand, eye and body protection. Use rubber gloves.

DO pour acid or bleach into the water. **DO NOT** pour water into acid or bleach solution.
DO NOT perform acid and bleach flushing at the same time. The gas generated by the mixture is poisonous and can result in serious injury or death.

To remove organic deposits from titanium tube bundle without removing the shell:

1. Isolate the heat exchanger. (see drawing next page)
2. Mix 1 part bleach to 3 parts distilled water in 20 gallon tank or larger container.
3. Circulate via pump the solution through heat exchanger for approximately one to two hours or as needed.
4. Thoroughly rinse heat exchanger with clean water.

To remove mineral deposits from titanium tube bundle:

Use the same steps as above, but use muriatic acid instead of bleach. Be sure to follow the muriatic acid manufacturer's instructions for use and safety.

Heat exchanger by-pass plumbing

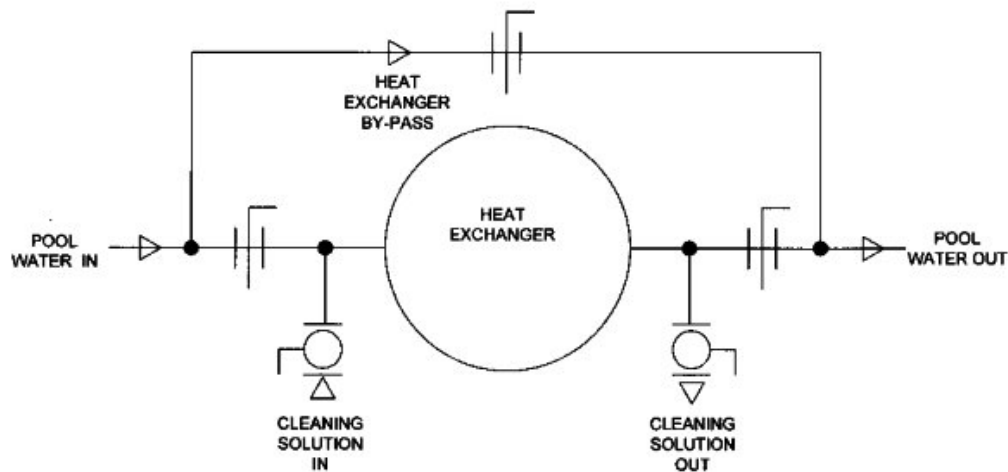

Condensing unit maintenance:

The condensing unit should be cleaned approximately every 12 months or as needed to allow proper performance.

Note: If located near the ocean, every 6 months a fresh water wash down of the condenser fins should be done to prolong the life of the chiller or heat pump.

1. Clean and inspect the condenser coil for dirt and debris built-up. (If dirty, use compressed air or a pressure washer to clean)
2. Visually inspect connecting refrigerant lines and coils for evidence of oil leaks. (If there is oil residue you may have a refrigerant leak. Call your local HVAC tech)
3. Check wiring for loose connections.

CHILLER AND HEAT PUMP PACKAGES LIMITED WARRANTY TERMS (PLEASE READ CAREFULLY):

Effective 3 / 2015

Limited Warranty

Aqua Logic, Inc. packaged water chiller and heat pumps have a **one (1) year** parts and **90 day** labor warranty. Heat exchanger (evaporator) has a **one (1) year** parts only warranty.

An extended condensing unit only five year parts and labor warranty is available for an additional charge. This must be added at the time of purchase.

The limited warranty covers only the parts and labor based upon Aqua Logic service cost and Aqua Logic is not liable for field repair work without prior written or verbal agreement with Repair Authorization (RA) number with a fixed maximum charge.

The warranty applies only to the original purchaser and is not transferable.

The warranty covers only the repair or replacement of Aqua Logic products and is limited to Aqua Logic's cost of defective parts.

Once Aqua Logic determines that the defect is due to parts or workmanship and that the product is under warrantee, Aqua logic will repair or replace the product solely at their discretion.

Our warranty does not include the following:

- Damage caused by freezing, inadequate or no water flow.
- Damage caused by improper installation or maintenance by user or their agent.
- Damage caused due to misapplication of the product.
- Damage caused by corrosion, abuse, accident, alteration or improper use.
- Damage caused by flood, fire, earthquake, tornado or other acts of God.
- Damage caused by electrical spikes, surges, brownouts or improper voltage or amperage.
- Damage caused by failure of any third party equipment (ie., controller, pump, etc.)
- Incidental damage to other equipment, property or livestock.
- Damage caused by a contractor in the field with poor installation technique ie., incorrect plumbing size between other equipment.

In the event of a defect or failure of the product, immediately contact Aqua logic for assistance. Aqua Logic will at their discretion:

- Provide user-replaceable parts to restore the unit to proper operation.
- Provide a Repair Authorization (RA) number with a specified dollar limit for a qualified technician to provide a field repair.
- Provide a Return Authorization (RA) number to return the unit with prepaid freight in wood crate that fully protects the unit from damage to: Aqua Logic, Inc., 9558 Camino Ruiz, San Diego, CA 92126
- Include the serial number as well as proof of purchase and /or a copy of the original bill of sale along with the RA number. COD shipments will be refused

Chiller / Heat Pump Start-up

Job Name			
Date			
Model No.			
Serial No.			
Unit Run Volts / phase			
Unit Run Amps			
Water flow rate (GPM)			
Incoming Water Temp (°F)			
Freon Suction (PSI)			
Freon Liquid (PSI)			
Superheat °F			

Start-up procedure:

Caution: It's important to allow the oil in the compressor(s) to warm-up at least 8 hours before starting up the unit. If the ambient air temperature is below 60°F, apply power to the unit and set controller so the compressor(s) do not energize or by-pass the heat exchanger water supply so the flow switch will not activate the unit.

1. Remove the cover of the unit. (If applicable)
2. Attach refrigeration suction and liquid hoses and an Amp / Volt meter to the unit.
3. Turn on water pump to heat exchanger. Note: (Make sure water flow rate is within published rate of the chiller.)
4. Adjust the controller below the indicated water temperature to turn on the unit. (After 2-5 minutes the compressor should activate.)
5. Once the compressor(s) are running for approximately 15 minutes, record the information that's listed above.
6. For Heat Pumps, cycle the unit from chilling to heating to make sure the reversing valve is functioning.

Comments:

Imbalance Voltage Tolerance in %
(% IMBALANCE flashes). The value may be adjusted by pressing the up and down arrows.

Lockout Time in seconds
(SECONDS flashes). The value may be adjusted by pressing the up and down arrows. (This is the delay on break timer value)

Delay time in seconds
(DELAY SECONDS flashes). The value may be adjusted by pressing the up and down arrows. This is the Random Start Delay value. (This is a delay on make timer)

Response time in seconds and tenths of seconds (RESP. SECONDS flashes) The value may be adjusted by pressing the up and down arrows. This is the time that a fault is allowed before shutdown occurs.

Control mode
(ON OFF AUTO flashes) The value may be adjusted to OFF (load will not turn on), ON (load will turn on whenever there are no faults and the timers are finished) and AUTO (load will turn on when there is a control input).

Contactors fault monitor mode
(CONTACTOR FAULT flashes) This option allows you to monitor the contactor and lock it out if the line voltage and load side varies by more than 5 volts. Pressing the up or down arrows selects off (default) or on. The load side of the contactor must be connected to the load terminals of the DTP-3 to use this option.

Display of fault memories
(MEM flashes) Pressing up or down displays the past fault conditions that took your unit off line. The first 25 faults are recorded. The top number displayed represents the fault memory. The middle number represents the total number of faults that have occurred since the fault memory was cleared.

To clear the memory, press and hold the up and down keys until the display is cleared.

Notes
If you press SELECT and do not change a parameter by pressing the up or down arrow keys, the DTP-3 automatically returns to displaying the line voltage in a few seconds.

The new settings are saved in permanent memory when the display returns to displaying the line voltage. The new settings may be verified by pressing the select button to sequence through the various parameters.

To prevent tripping on a 1 volt change, the DTP-3 automatically calculates cut-in voltages for return from undervoltage conditions. The cut-out voltage is always based on the user voltage and tolerance settings, while the cut-in voltage is 3% closer to the nominal voltage setting. This quality is sometimes referred to as hysteresis. This is to help reduce oscillation that may occur on weak power distribution systems. When the load is switched off due to undervoltage, the line voltage will increase. Without the hysteresis, the monitor would switch the load back on, the line voltage would again drop, and cause a continuous on-off-on cycling.

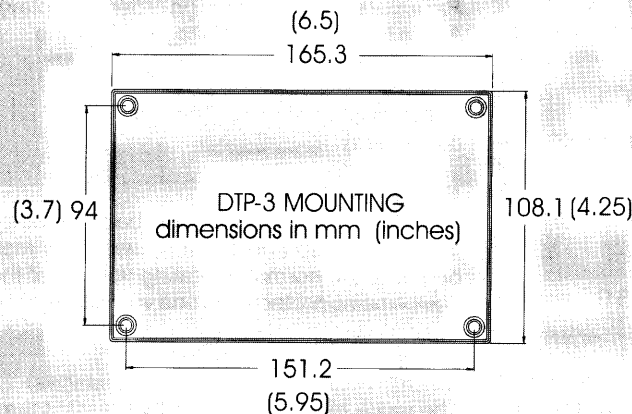

Product of DiversiTech Corp.
www.diversitech.com
Designed in U.S.A.
assembled in China

DTP-3
Digital Three Phase

Motor Protector / Power Monitor
Installation and Operation Instructions



KEY FEATURES

- ✓ Digital voltmeter displays instantaneous line voltage for all 3 phase pairs
- ✓ Contactor load side monitor checks for contactor closure
- ✓ One button contactor load side voltage measurement
- ✓ Automatic voltage tester adjusts from 160 to 600 volts
- ✓ Adjustable response timer (0.1 to 20 sec.) prevents nuisance tripping
- ✓ Adjustable delay on break (DOB) timer (0 to 720 sec.) prevents rapid re-starts
- ✓ Adjustable timer (0 to 30 sec.) allows sequencing of multiple units
- ✓ Off, Auto, On settings for operation with or without control inputs
- ✓ Selectable contactor test. Opens contactor if any one of 3 circuits fail
- ✓ Digital display makes for easy viewing and operation
- ✓ Fault memory records up to 25 fault causes

SPECIFICATIONS

✓ Voltmeter:	70 to 650 Volts: simultaneous display of AB BC CA voltages
✓ Accuracy	+ / - 2% of indicated average voltage
✓ Tolerance Limits:	6 to 18%
✓ Imbalance:	2 to 25%
✓ Response Timer:	0.1 to 20 seconds
✓ DOB Timer:	0 to 720 seconds
✓ Delay Timer:	0 to 30 seconds
✓ Contactor Test	Contactors opens and remains locked out if voltage difference is 5 volt for any phase pair.
✓ Output Relay:	10 Amps, 250 VAC resistive, single-pole/double-throw
✓ Control Input:	18 to 250 VAC with anticipator load for 24 volt thermostats

OVERVIEW

The DTP-3 Line Voltage Monitor provides continuous monitoring of the power and control signals used to operate any three phase load. Protected devices can include motors, pumps, fans, compressors and other devices.

The DTP-3 protects these devices by keeping a constant watch over the supplied voltage, and when the voltage goes outside of a voltage and tolerance that you select, the DTP-3 opens its control relay.

The time required to respond to the out-of-tolerance conditions is user adjustable and may be set for shorter times for sensitive devices or longer times to help eliminate nuisance tripping.

Each of the three line voltage pairs are

checked for voltage level and phase to phase balance. Further testing of the system includes contactor-load-side monitoring. When enabled, the load side monitor checks the contactor for closure. If the contactor load side voltage does not match the line side voltage to 5 volts within 0.5 seconds after the control relay closes, the control relay is opened and remains locked out until power to the DTP-3 is cycled off and on.

Additionally, phase rotation is tested. If the rotation is reversed, operation of the output relay is inhibited.

If any of the limits that you set are exceeded, the response timer will begin counting. You also have the flexibility to set the response timer -- a short time may be desired for a quick response or a long time may be desired to avoid nuisance tripping. If the voltage

remains outside the tolerance after the response time has elapsed, the DTP-3 will turn off its output relay and protect your device.

When the DTP-3's relay opens, the delay timer starts. This timer keeps track of the time since the output was turned off and prevents the protected equipment from restarting too soon. The delay is also user adjustable. It is particularly useful for the protection of

or compressor contactor.

The DTP-3 should be mounted on a metal surface with four #8 sheet metal screws. Mounting on a metal surface helps dissipate heat and shield the DTP-3 from nearby equipment radiation.

WIRING

If the voltage being monitored is tapped from a high current source, branch circuit protection

load side to the DTP-3's T1, T2 and T3 terminals. Note that the load side monitoring should also include the required fusing to meet the branch circuit protection requirements of the National Electric Code or locale equivalent. If installed, the contactor fault option should be set to "ON".

NC, NO and COM

These terminals connect to the relay output. The relay closes when the line voltage is within the selected tolerance, the control voltage is on and the delay timer has expired. Typically you would connect the COM and NO terminals in series with the control circuit, motor starter or contactor coil.

C1, C2 and C3

Connect a control voltage to C1 and C2. The DTP-3 responds to voltage between 18 and 250 Volts and draws only a fraction of an Amp. An internal anticipator load is provided by connecting C2 to C3 to allow the use of a 24 Volt thermostat. Be sure to only connect C3 for 24 Volt or lower operation.

SETUP

The DTP-3 may be setup at a shop or other location prior to installation by simply applying power to any of the three line-side phase pairs. The DTP-3 will power up on single phase power and allow the setting of user parameters prior to installation in a three phase system. After completing the installation (or for stand-alone setup), apply power to the DTP-3. The DTP-3 display will show a brief display test followed by the firmware revision number. The DTP-3 will then indicate the remaining time on any active timers. If the timers are expired the incoming line voltage will be displayed. The OVERVOLTAGE, UNDERVOLTAGE, PHASE LOSS and/or the PHASE REVERSAL indicators may also be visible depending on the factory settings versus your incoming line voltage.

During any point in the DTP-3's operation, you may read the incoming voltage by pressing the SELECT button to return to the AB BC CA voltmeter. (Normal Display)

THE DISPLAY

The display normally shows the AB BC and CA line voltages.

If the unit is waiting on a timer, that timer will be displayed. The timer display may be switched off by pressing SELECT. The LCD will then

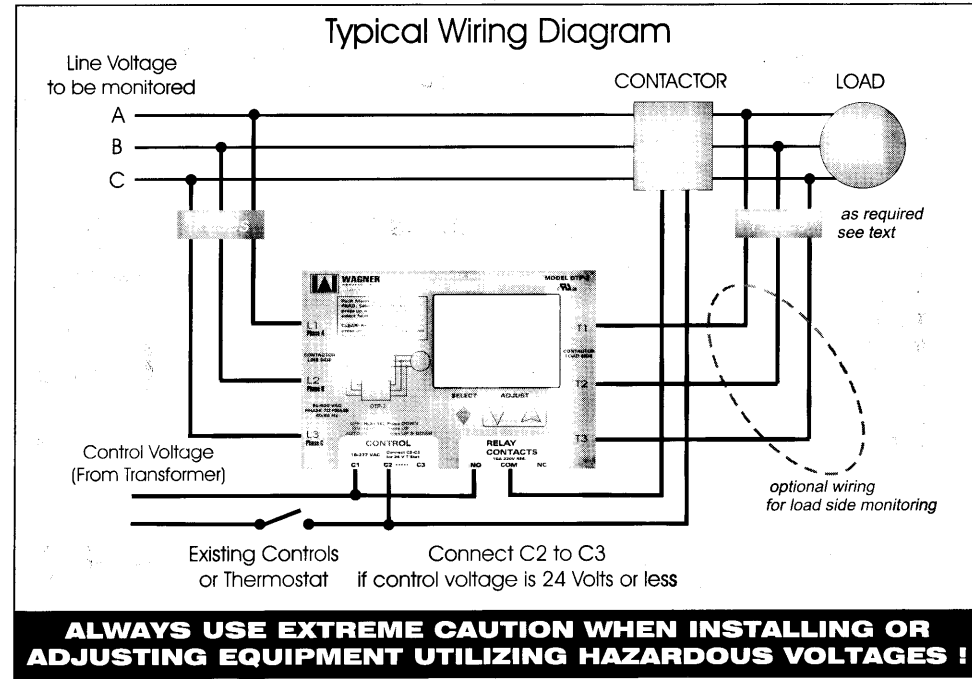

compressors, where an attempted rapid restart can cause a stalled condition and motor burnout.

DISCONNECT ALL POWER BEFORE STARTING THE INSTALLATION OF THE DTP-3

INSTALLATION

Installation of the DTP-3 is simple and straight forward.

MOUNTING

Select a cool, dry location for the mounting of the DTP-3. Keep in mind that the front of the unit has the operator controls and the digital display. The front of the DTP-3 should be clear of obstructions and allow easy access to the control buttons. A suitable location may be in the control enclosure, near the motor starter

(fuse or circuit breaker as described in the National Electric Code) should be provided. Since the current drawn by the DTP-3 is a fraction of an Amp, the branch protection can be selected for the wire type used. Typically, fuses rated at 1 Amp will provide the required protection. If the load side monitor option is utilized, it's wiring must also be current limited.

PINOUT DESCRIPTION

L1, L2 and L3

Connect the voltage being monitored to the DTP-3's L1, L2, and L3 terminals. This voltage will also power the DTP-3 and should come from a source such as the line side of the contactor being controlled.

T1, T2 and T3

If your application requires contactor load side monitoring, you should connect the contactor

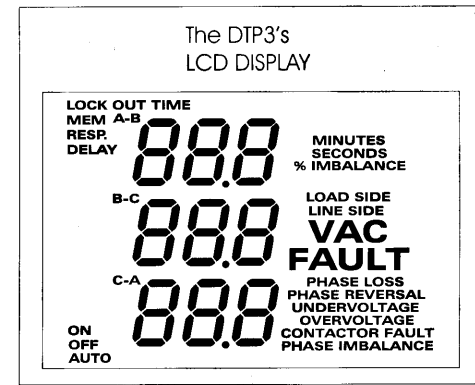

display the normal AB BC CA voltage pairs.

Pressing the SELECT button once shows the contactor load side voltages. (if the load side option is connected) The display automatically returns to the display of line side voltage after a few seconds.

Press the Select button to step through the parameters. As you step through the parameters, the selected parameter will flash. Use the up and down arrow keys to adjust to the desired operating value.

- Line side voltage
- Load side voltage
- Voltage set point
- Under/over voltage tolerance in %
- Imbalance voltage tolerance in %
- Lockout time in seconds
- Delay time in seconds
- Response time in seconds
- Control mode
- Contactor fault monitor
- Fault Memory Display

Parameters adjustment (in order of display)
Active display of Line Voltage (this is the default normal display)

Active display of Load Side Voltage (if connected)

Voltage Set Point (VAC Flashes) The value may be adjusted by pressing the up and down arrows. This may be set to the normal operating voltage of the device being protected in one volt increments.

Under/over Voltage Tolerance in % (UNDERVOLTAGE/OVERVOLTAGE flashes) The value may be adjusted by pressing the up and down arrows.



ICM450

Programmable Three Phase Voltage Monitor with 25-Fault Memory

Protects motors from premature failure and burnouts



Installation, Operation & Application Guide

For more information on our complete range of American-made products – plus wiring diagrams, troubleshooting tips and more, visit us at www.icmcontrols.com



Specification

Input

- **Line Voltage:** Universal, 190-630 VAC
- **Frequency:** 50-60 Hz
- **Load Side Monitoring:** Optional
- **Control Voltage:** 18-240 VAC
- **Frequency:** 50-60 Hz

Output

- **Type:** Relay, SPDT
- **Voltage Range:** 240VAC @ 10A maximum
- **Frequency:** 50-60 Hz

Control Operating Temperature

- **Operating Temperature:** -40°F to +167°F (-40°C to +75°C)
- **Storage Temperature:** -40°F to +185°F (-40°C to +80°C)

LCD Operating Temperature

- **Operating Temperature:** -4°F to +167°F (-20°C to +75°C)

Mechanical

- **Mounting:** Surface mount using (2) #8 screws
- **Terminations:** Screw terminals
- **Weight:** 12 ounces (341 grams)

Dimensions

- 6 1/2" L, 4 1/4" W, 1 3/8" H (16.5 cm. L, 10.8 cm. W, 3.5 cm. H)

Parameters

Phase Unbalance Protection

- **Voltage Unbalance:** 2-20% adjustable

Over/Under Voltage Protection

- **Under Voltage:** 2-25% adjustable
- **Over Voltage:** 2-25% adjustable

Phase Loss Protection

- **Phase Loss Condition:** Equals 25% of nominal for any given phase; system will shut down and a fault will be recorded should this occur

Delay on Break Timer

- **Control Voltage:** 18-240 VAC
- **Time Delay:** 0 to 10 minutes adjustable

Fault Interrogation Delay

- **Time Delay:** 0 to 15 seconds adjustable
- Provides a delay between fault detection and system shutdown - helps to eliminate nuisance trips or unnecessary shutdowns

Caution

Installation of the ICM450 shall be performed by trained technicians only. Adhere to all local and national electric codes.

Disconnect all power to the system before making any connections.

Installation

1. Using (2) #8 screws, mount the **ICM450** in a cool, dry, easily accessible location in the control panel.
2. Connect voltage as shown in Figure 1 (below). Leave existing line and load side connections intact on the contactor.
3. Load side monitoring is optional (unit may be used to monitor line side only). Wire the contactor and optional control voltage monitoring as in Figures 2 and 3 (below).
** **Note:** Load/line wire must be rated for 3-phase voltage rating, 20ga minimum.
4. Upon application of power, the **ICM450** will be on line and will begin to monitor the system.

Figure 1

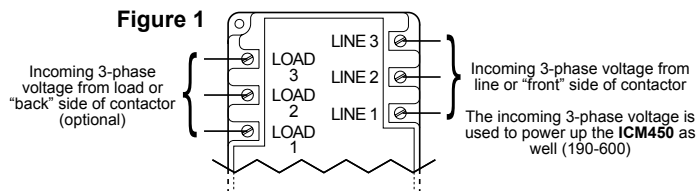

- Terminals 1 and 3 are the control signal input terminals
- "Control Mode" is turned ON or OFF in setup
- With "Control Mode" set to "ON," there must be a voltage present on terminals 1 and 3 for the relay output terminals 4 and 6 to close; this voltage can be supplied from a thermostat, pressure switch, etc.
- When the voltage on these terminals is re-applied, the unit will not re-energize until the delay on break (0-10 minutes) time has elapsed
- Use of terminals 1 and 3 is optional; they will be ignored if the "Control Mode" is set to "OFF"

Figure 2

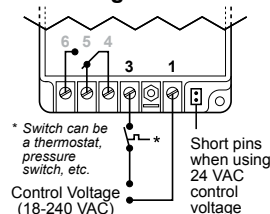

- Terminals 4 and 6 are "dry," normally open contacts
- Terminals 4 and 6 are closed when power is within specifications
- Terminals 4 and 6 open when there is a fault condition
- Terminals 4 and 6 open when there is a loss of the control signal with "Control Mode" set to "ON"

Figure 3

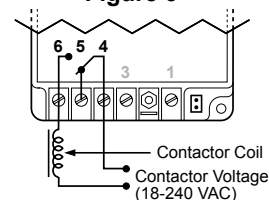

ICM450 Wiring Diagrams

2-Pole Contactor

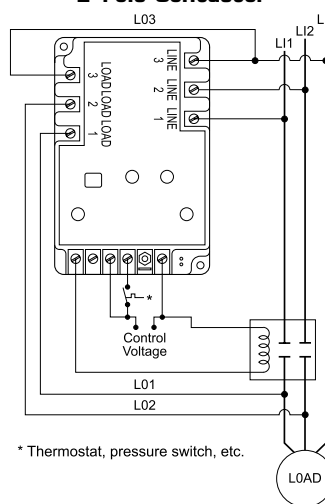

3-Pole Contactor

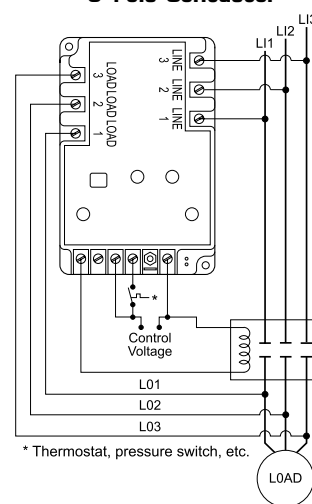

Setting the Parameters

1. Press the green **SETUP** button to enter Setup mode. Setup LED will light.
2. Use the ∇ and \blacktriangle arrows to change user parameters.
3. Scroll through setup by pressing and releasing the **SETUP** button.
4. When the last parameter has been set, the phase average will be displayed and the Setup LED will automatically turn OFF.

Button Functions



Press arrows to scroll through and select user parameter settings in Setup mode. HOLD down for fast edit.



Press to enter Setup mode and select user parameters.



Hold for voltage display a \rightarrow b, b \rightarrow c, a \rightarrow c (simultaneously).



Press to read faults. Hold for 5 seconds to clear faults and reset memory.

Parameter	Description	Range	Default	Recommended
Line Voltage	Average phase to phase line voltage	190-600	208	Nameplate Voltage
Delay On Break	Amount of time between the load de-energizing and re-energizing	0-10 minutes	.1 minute	4 minutes**
Fault Interrogation	Amount of time before the load de-energizes due to a non-critical fault*	0-15 seconds	15 seconds	7-8 seconds**
% Over/Under Voltage	Maximum/minimum phase to phase average voltage, respectively	2-25%	20%	12-15%**
% Phase Unbalance	Amount of allowable voltage unbalance	2-20%	20%	4-5%**
Reset Mode	AUTO or number of times the load can be re-energized after a load side fault before a manual reset is necessary ** Note: When monitoring line side only, the reset mode will always be AUTO	AUTO, 0-10	AUTO	AUTO
Control Mode	With control mode set to OFF, the load will energize if no 3- phase fault conditions exist; with control mode ON, the load will energize if no fault conditions exist and control voltage is present at terminals 1 and 3 of the ICM450	ON or OFF	ON	Based on wiring

* Non-critical faults are faults such as High/Low Voltage and Phase Unbalance. Critical faults, such as Phase Loss and Phase Reversal, have a fault interrogation of under 2 seconds and it is not user adjustable.

** For best recommendations, consult manufacturer of equipment.

Fault Conditions

Press and release fault button to scroll through all saved faults.

** Note: For initial setup, press and hold FAULT for 5 seconds to remove any previously stored faults.

Fault	Problem	Corrective Action
Back Phase Loss	Not all three of the phases on the load side are present	1. Re-energize the contactor. 2. If the fault reappears after the load energizes: a. Turn all power OFF b. Check all load side connections c. Check the contacts of the contactor for debris or excess carbon.
Back Phase Rev	Loads 1, 2, or 3 are not in sequence (not 120° phase shifted)	1. Turn OFF all power. 2. Swap any 2 phases on the load side of the ICM450 only (example: swap load 1 and load 2) * 3. Re-apply power.
Back Phase Unbalance	A voltage unbalance between the three load phases exceeds the unbalance setpoint	1. Press the READ button to observe the present load voltages. Check system for unbalance cause. 2. Increase the fault interrogation time if necessary. 3. Increase the percent unbalance setting if necessary.
Front Over Voltage	Average phase-phase voltage exceeds the maximum percentage	1. Check system for over-voltage cause. 2. Increase the percent over-voltage setting if necessary. 3. Increase the fault interrogation time if necessary.
Front Phase Loss	Not all three of the phases on the line side are present	1. Press and hold the READ button on the phase monitor or use an AC voltmeter to carefully measure all three phase-phase line voltages (example: Line 1 → Line 2, Line 2 → Line 3, Line 3 → Line 1). 2. Repair the missing phase.
Front Phase Reversal	Lines 1, 2, or 3 are not in sequence (not 120° phase shifted)	1. Turn OFF all power. 2. Swap any 2 phases on the line side of the ICM450 (example: swap Line 1 and Line 2)* 3. Re-apply power.
Front Phase Unbalance	A voltage unbalance between the three line phases exceeds the unbalance setpoint	1. Press the READ button to observe the present load voltages. Check system for unbalance cause. 2. Increase the fault interrogation time if necessary. 3. Increase the percent unbalance setting if necessary.
Front Under Voltage	Average phase-phase voltage is below the minimum percentage	1. Check system for under-voltage cause. 2. Increase the percent under-voltage setting if necessary. 3. Increase the fault interrogation time if necessary.

* Only swap phases during initial setup, not after the ICM450 has been in operation without errors.

Troubleshooting

Problem	LCD Readout	LED Status	Corrective Action
Load will not energize	Phase Average	All LEDs Off	Confirm that the control input (terminals 1 & 3) is properly connected and configured
Load will not energize	Phase Average	Load LED Off, Fault LED blinking	Press FAULT once to observe the current fault; correct the condition of the first fault that appears (see Fault Conditions above, for a list of corrective actions)
Fault LED blinks repeatedly while load is energized	Phase Average	Fault LED Blinking, Load LED On	Indicates there are faults saved in the memory, press FAULT rapidly to scroll through saved faults; to clear the faults, press and hold FAULT for more than 5 seconds
Load will not de-energize when control voltage is OFF	Phase Average	Load LED On, Control LED Off	The control mode setting is OFF; press SETUP to get to the control mode. Press ^ to set the control mode ON
Setup LED is on while load is being energized	Anything Other Than Phase Average	Setup LED On, Load LED On	To exit the setup mode, press either READ or FAULT
Load will not energize	Reset	Fault LED Blinking	Unit in lockout; maximum number of retries in manual reset mode has been reached; to reset unit, press FAULT and hold for more than 5 seconds
Load turns ON and OFF repeatedly	Readout is Irrelevant	Fault LED Blinking	Fix load side fault; press FAULT to observe condition; the delay on break period may be too short; press SETUP to enter the delay on break mode; press ^ to lengthen the delay

ONE-YEAR LIMITED WARRANTY

The Seller warrants its products against defects in material or workmanship for a period of one (1) year from the date of manufacture. The liability of the Seller is limited, at its option, to repair, replace or issue a non-case credit for the purchase prices of the goods which are provided to be defective. The warranty and remedies set forth herein do not apply to any goods or parts thereof which have been subjected to misuse including any use or application in violation of the Seller's instructions, neglect, tampering, improper storage, incorrect installation or servicing not performed by the Seller. In order to permit the Seller to properly administer the warranty, the Buyer shall: 1) Notify the Seller promptly of any claim, submitting date code information or any other pertinent data as requested by the Seller. 2) Permit the Seller to inspect and test the product claimed to be defective. Items claimed to be defective and are determined by Seller to be non-defective are subject to a \$30.00 per hour inspection fee. This warranty constitutes the Seller's sole liability hereunder and is in lieu of any other warranty expressed, implied or statutory. Unless otherwise stated in writing, Seller makes no warranty that the goods depicted or described herein are fit for any particular purpose.





Patent No. 424,953

7313 William Barry Blvd., North Syracuse, NY 13212
(Toll Free) 800-365-5525 (Phone) 315-233-5266 (Fax) 315-233-5276

www.icmcontrols.com

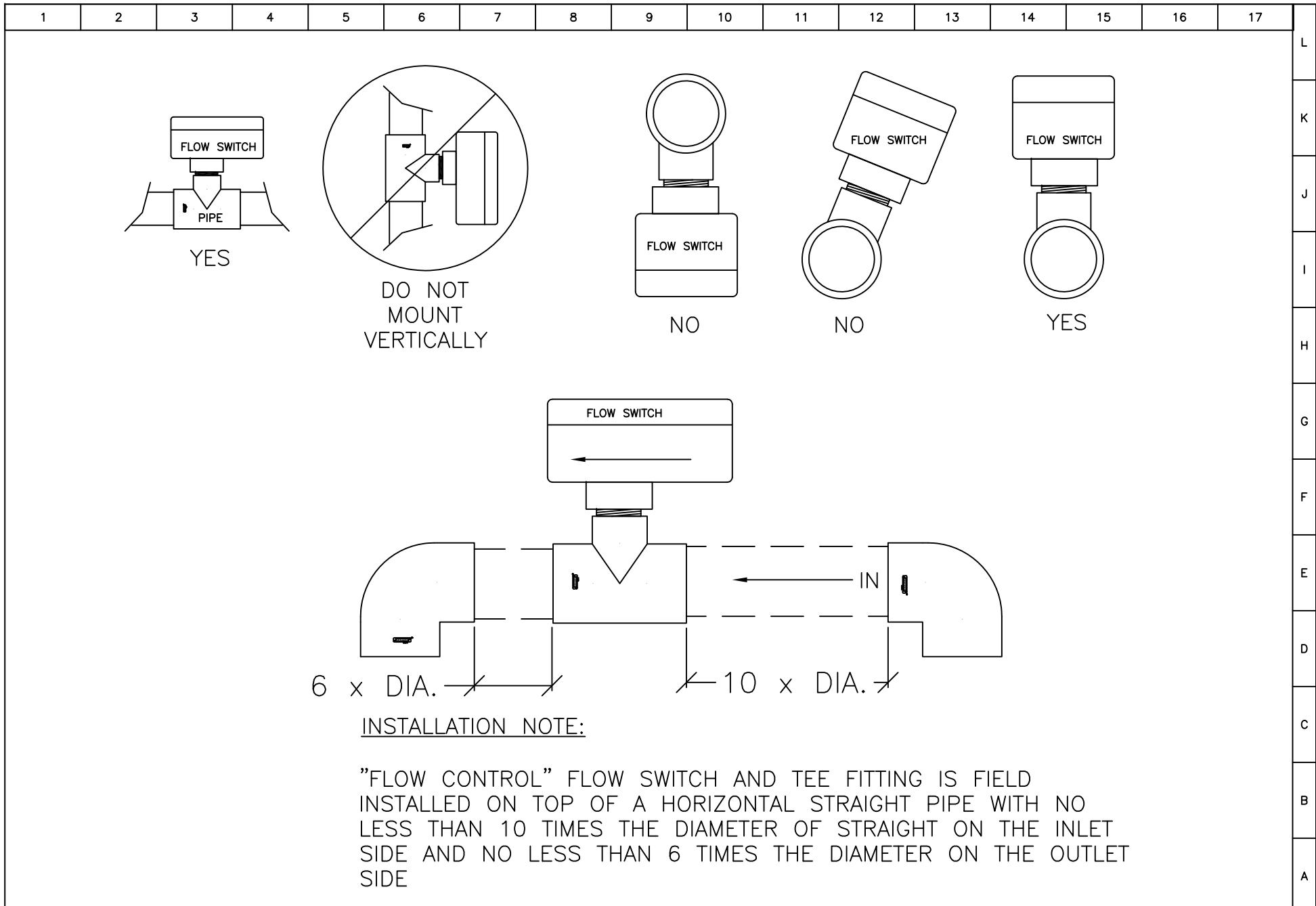
LIAF043-1



TITLE	FLOW SWITCH PLUMBING NOTE	PROJECT	FLOW SWITCH	FILE	C:\AutoCad Files\Controls\3in Flow Switch Plumbing Note 4-24-13.dwg	DRAWING NO	FS-01	EDITED	7/1/2015	SCALE	1:1	 AQUA LOGIC, INC 9558 CAMINO RUIZ, SAN DIEGO, CA 92126
		CLIENT	AQUA LOGIC INC			DRAWN BY	CEPPS	CREATED	4/24/2013	PAGE	1 of 1	

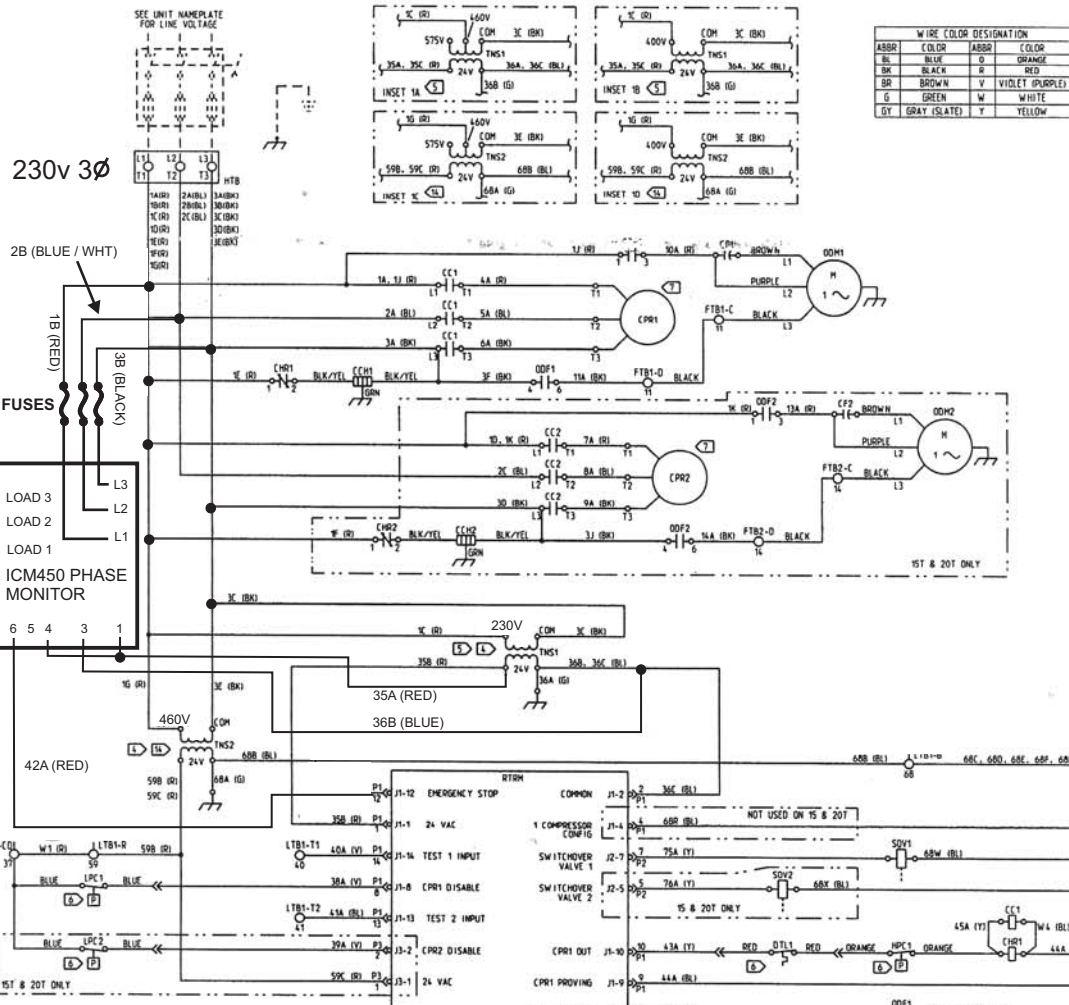

DEVICE	DESCRIPTION	LINE
CC1	COMPRESSOR CONTACTOR	9, 10, 11, 29
CC2	COMPRESSOR CONTACTOR	14, 15, 16, 40
CH1	CRANKCASE HEATER	17
CH2	CRANKCASE HEATER	17
CF1	OUTDOOR FAN CAPACITOR	6
CF2	OUTDOOR FAN CAPACITOR	13
CH1	CRANKCASE HEATER RELAY	17, 30
CH2	CRANKCASE HEATER RELAY	17, 30
COMM	COMMUNICATION INTERFACE MODULE	50
CP1	COMPRESSOR	10
CP2	COMPRESSOR	15
CT51	OUTDOOR COIL TEMP SENSOR	57
CT52	OUTDOOR COIL TEMP SENSOR	57
D11	DISCHARGE TEMPERATURE LIMIT	30
D12	DISCHARGE TEMPERATURE LIMIT	39
F1	FAN TERMINAL BLOCK	10, 12, 18
F2	FAN TERMINAL BLOCK	15, 17
HP1	HIGH PRESSURE CUTOUT	30
HP2	HIGH PRESSURE CUTOUT	39
HTB	HIGH VOLTAGE TERMINAL BLOCK	5
LP1	LOW PRESSURE CUTOUT	28
LP2	LOW PRESSURE CUTOUT	30
L1	LOW VOLTAGE TERMINAL BLOCK	24, 27, 29, 43, 44, 45
L2	LOW VOLTAGE TERMINAL BLOCK	23, 25, 44, 45
L3	OUTDOOR AIR TEMP SENSOR	17
OD1	OD FAN RELAY	6, 10, 32
OD2	OD FAN RELAY	13, 17, 37
ODM1	OUTDOOR FAN MOTOR	8
ODM2	OUTDOOR FAN MOTOR	11
PH	PHASE MONITOR	9, 22
R1	DELTA/STAR REVERSATION MODULE	26
SDV1	SWITCH-OVER VALVE	27
SDV2	SWITCH-OVER VALVE	28
TS1	TRANSFORMER - CONDENSER	20
TS2	TRANSFORMER - CONDENSER	23

WARNING
HAZARDOUS VOLTAGE!
DISCONNECT ALL ELECTRIC POWER INCLUDING REMOTE DISCONNECTS AND FOLLOW LOCK OUT AND TAG PROCEDURES BEFORE SERVICING. INSURE THAT ALL MOTOR CAPACITORS HAVE DISCHARGED STORED VOLTAGE. UNITS WITH VARIABLE SPEED DRIVE, REFER TO DRIVE INSTRUCTIONS FOR CAPACITOR DISCHARGE.

AVERTISSEMENT
TENSION DANGEREUSE!
COUPER TOUTES LES TENSIONS ET OUVRIER LES SECTIONNEURS A DISTANCE. PUIS SUIVRE LES PROCEDURES DE VERROUILLAGE ET DES ETIQUETTES AVANT TOUTE INTERVENTION. VERIFIER QUE TOUTS LES CONDENSATEURS DES MOTEURS SONT DECHARGES. DANS LE CAS D'UNITES EQUIPEES DE VITESSE VARIABLE, CONSULTER LES INSTRUCTIONS DE VITESSE VARIABLE POUR VITESSE VARIABLE. SE REPORTER AUX INSTRUCTIONS DE VITESSE VARIABLE POUR DECHARGER LES CONDENSATEURS.

ADVERTENCIA
¡VOLTAJE PELIGROSO!
DESCONECTE TODA LA ENERGÍA ELÉCTRICA, INCLUIDO LAS DESCONEXIONES REMOTAS Y SIGA LOS PROCEDIMIENTOS DE CIERRE Y ETIQUETADO ANTES DE PROCEDER AL SERVICIO. ASEGURESE DE QUE TODOS LOS CAPACITORES DEL MOTOR HAYAN DESCARGADO EL VOLTAJE ALMACENADO. PARA LAS UNIDADES CON EJE DE DIRECCIÓN DE VELOCIDAD VARIABLE, CONSULTE LAS INSTRUCCIONES PARA LA DESCARGA DEL CONDENSADOR.

CAUTION
USE COPPER CONDUCTORS ONLY!
UNIT TERMINALS ARE NOT DESIGNED TO ACCEPT OTHER TYPES OF CONDUCTORS.
FAILURE TO DO SO MAY CAUSE DAMAGE TO THE EQUIPMENT.

ATTENTION
N'UTILISER QUE DES CONDUCTEURS EN COUPE!
LES BORNES DE L'UNITÉ NE SONT PAS CONÇUES POUR RECEVOIR D'AUTRES TYPES DE CONDUCTEURS.

PRECAUCION
UTILICE ÚNICAMENTE CONDUCTORES DE COBRE!
LAS TERMINALES DE LA UNIDAD NO ESTÁN DISEÑADAS PARA ACEPTAR OTROS TIPOS DE CONDUCTORES.
SI NO SE HACE, PUEDE OCASIONAR DAÑO AL EQUIPO.



Ph: (858) 292-4773
Fax: (858) 279-0537

HP-6 Thru HP-20
230v 3ϕ
9/22/14 R-410A

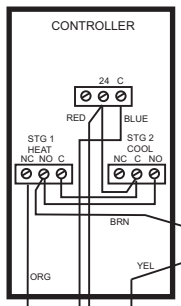

15 & 20 HP JUMPER

J7 BLOCK ON RTM BOARD

- NOTES**
- UNLESS OTHERWISE NOTED, ALL SWITCHES ARE SHOWN AT 25°C (77°F) AT ATMOSPHERIC PRESSURE, AT 50% RELATIVE HUMIDITY, WITH ALL UTILITIES TURNED OFF, AND AFTER A NORMAL SHUTDOWN HAS OCCURRED.
 - DASHED LINES INDICATE RECOMMENDED FIELD WIRING BY OTHERS. DASHED LINE ENCLOSURES AND/OR DASHED DRIVE OUTLINES INDICATE COMPONENTS PROVIDED BY THE FIELD. PHANTOM LINE ENCLOSURES INDICATE ALTERNATE CIRCUITRY OR AVAILABLE SALES OPTIONS. SOLID LINE INDICATES WIRING BY TRANE CO.
 - NUMBERS ALONG THE RIGHT SIDE OF THE SCHEMATIC DESIGNATE THE LOCATION OF CONTACTS BY LINE NUMBER. AN UNDERLINED NUMBER INDICATES A NORMALLY CLOSED CONTACT. AN OPEN ARROWHEAD BELOW THE LINE NUMBER POINTING UPWARD INDICATES A TIMED CONTACT WHICH BEGINS TIMING WHEN ENERGIZED.
 - CONNECTIONS SHOWN ARE FOR 230V/60Hz/3PH UNITS. FOR 208V/60Hz/3PH OPERATION IS REQUIRED, MOVE WIRES 1E (R) AND 1B (Y) FROM 230V TERMINAL ON UNIT TRANSFORMERS (TS1 AND TS2) TO 200V TERMINAL.
 - CONNECTIONS SHOWN ARE FOR 230V/60Hz/3PH UNITS. FOR 460V/60Hz/3PH MODELS, SEE INSET 1A. FOR 575V/60Hz/3PH MODELS, CONNECT WIRE 1E (R) TO THE 575V TERMINAL ON TS1. FOR 380-415V/50Hz/3PH MODELS, SEE INSET 1B.
 - CAUTION: DO NOT JUMPER ACROSS SWITCHES D11, D12, LP1, LP2, HP1 AND HP2 UNDER ANY CIRCUMSTANCES.
 - NOTICE: DO NOT OPERATE OR APPLY POWER TO COMPRESSORS WHILE UNDER A VACUUM. FAILURE TO FOLLOW THESE INSTRUCTIONS WILL RESULT IN COMPRESSOR FAILURE.
 - INSTALL OPTIONAL REMOTE ZONE SENSOR TO TERMINALS S1 AND S2 WHEN REQUIRED. SEE PROGRAMMABLE ZONE SENSOR W/ NSB LITERATURE FOR OPTION CONFIGURATION.
 - THE DAS ON 15T AND 20T UNITS IS CONNECTED AS SHOWN. ON SMALLER UNITS, WIRES S0A AND S0A ARE NOT PRESENT AND THE BROWN LEADS ARE CONNECTED DIRECTLY TO THE RTM.
 - IF EVAPORATOR DEFROST CONTROL (EDC) IS USED ON INDOOR UNIT, REMOVE JUMPER WIRE W1 (R) BETWEEN TERMINALS "CO" AND "R" ON LTB1.
 - SEE HEATER ACCESSORY DIAGRAM FOR DETAILS OF HEATER WIRING.
 - TO ENABLE ELECTRIC HEAT, CUT WIRE 55A (BR) ON P2.
 - TO ENABLE TWO STAGES OF ELECTRIC HEAT, CUT WIRE 49A (BR) ON P1.
 - CONNECTIONS SHOWN ARE FOR 230V/60Hz/3PH UNITS. FOR 460V/60Hz/3PH MODELS, SEE INSET 1A. FOR 575V/60Hz/3PH MODELS, CONNECT WIRE 1E (R) TO THE 575V TERMINAL ON TS1. FOR 380-415V/50Hz/3PH MODELS, SEE INSET 1B.
 - TO ENABLE COMPRESSOR LEAD/LAG OPERATION, CUT WIRE 68D (BL).

TRANE
CONDENSER UNIT - HEAT PUMP
617 517 5171 TALL UNIT TEST 8
10120T 380-415V/50Hz/60Hz / 380-415V/50Hz

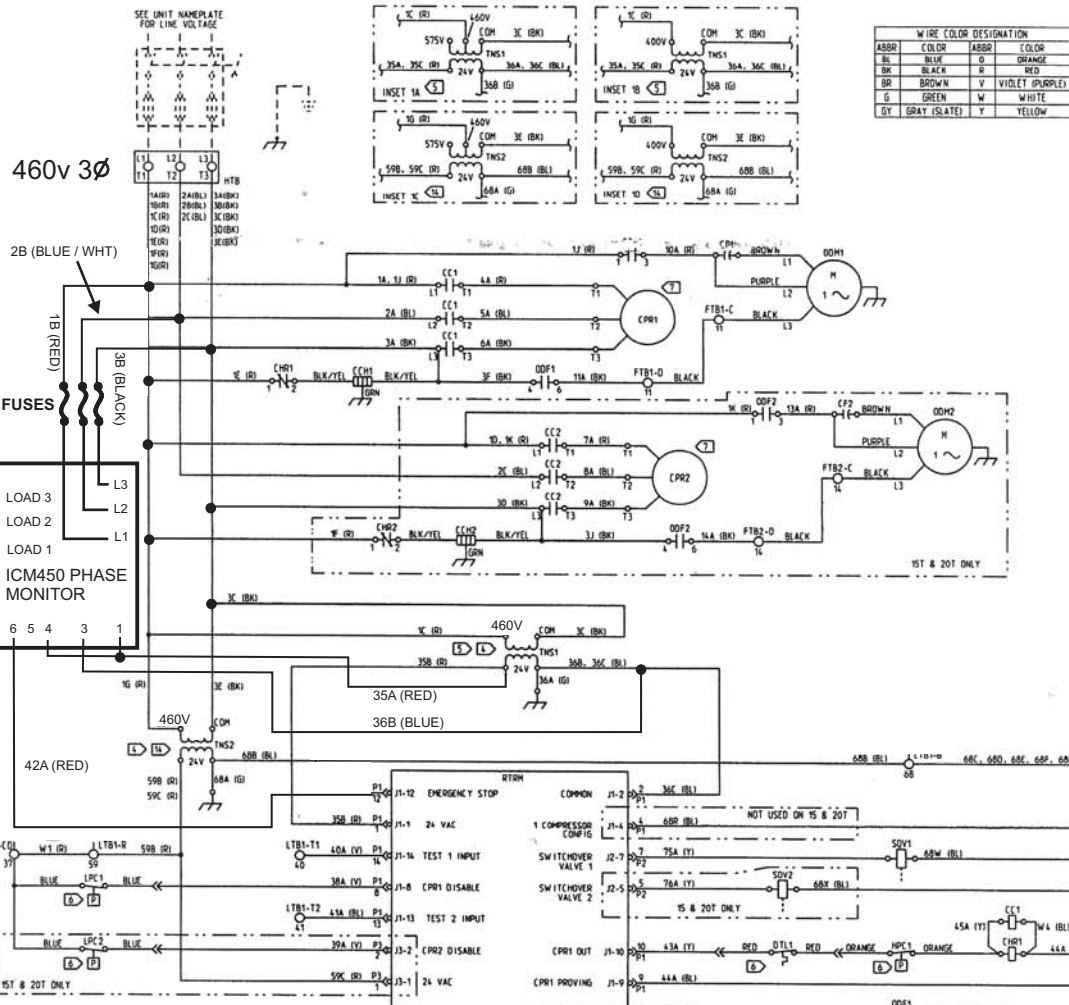

WIRE COLOR	ABBV	COLOR
BL	BLU	BLUE
BR	BRN	BROWN
GY	GRY	GRAY
WH	WHT	WHITE
OR	ORG	ORANGE
RD	RED	RED
VT	VIO	VIOLET
Y	YEL	YELLOW

DEVICE	DESCRIPTION	LINE
CC1	COMPRESSOR CONTACTOR	9, 10, 11, 29
CC2	COMPRESSOR CONTACTOR	14, 15, 16, 40
CH1	CRANKCASE HEATER	17
CH2	CRANKCASE HEATER	17
CF1	OUTDOOR FAN CAPACITOR	6
CF2	OUTDOOR FAN CAPACITOR	13
CH1	CRANKCASE HEATER RELAY	17, 30
CH2	CRANKCASE HEATER RELAY	17, 30
COMM	COMMUNICATION INTERFACE MODULE	50
CP1	COMPRESSOR	10
CP2	COMPRESSOR	15
CT51	OUTDOOR COIL TEMP SENSOR	57
CT52	OUTDOOR COIL TEMP SENSOR	57
D11	DISCHARGE TEMPERATURE LIMIT	30
D12	DISCHARGE TEMPERATURE LIMIT	39
FTB1	FAN TERMINAL BLOCK	10, 12, 18
FTB2	FAN TERMINAL BLOCK	15, 17
HP1	HIGH PRESSURE CUTOUT	30
HP2	HIGH PRESSURE CUTOUT	39
HTB	HIGH VOLTAGE TERMINAL BLOCK	5
LP1	LOW PRESSURE CUTOUT	28
LP2	LOW PRESSURE CUTOUT	30
L1B1	LOW VOLTAGE TERMINAL BLOCK	24, 27, 29, 43, 44, 45
L1B2	LOW VOLTAGE TERMINAL BLOCK	23, 25, 44, 45
OAS	OUTDOOR AIR TEMP SENSOR	17
OD1	OD FAN RELAY	8, 10, 32
OD2	OD FAN RELAY	13, 17, 37
ODM1	OUTDOOR FAN MOTOR	8
ODM2	OUTDOOR FAN MOTOR	13
PH	PHASE MONITOR	9, 22
RTM	RELEASER/REGENERATION MODULE	26
SDV1	SWITCH-OVER VALVE	27
SDV2	SWITCH-OVER VALVE	28
TS1	TRANSFORMER - CONDENSER	20
TS2	TRANSFORMER - CONDENSER	23

WARNING
HAZARDOUS VOLTAGE!
DISCONNECT ALL ELECTRIC POWER INCLUDING REMOTE DISCONNECTS AND FOLLOW LOCK OUT AND TAG PROCEDURES BEFORE SERVICING. INSURE THAT ALL MOTOR CAPACITORS HAVE DISCHARGED STORED VOLTAGE. UNITS WITH VARIABLE SPEED DRIVE, REFER TO DRIVE INSTRUCTIONS FOR CAPACITOR DISCHARGE.

AVERTISSEMENT
TENSION DANGEREUSE!
COUPER TOUTES LES TENSIONS ET OUVRIRE LES SECTIONNEURS A DISTANCE. PUIS SUIVRE LES PROCEDURES DE VERROUILLAGE ET DES ETIQUETTES AVANT TOUTE INTERVENTION. VERIFIER QUE TOUTS LES CONDENSATEURS DES MOTEURS SONT DECHARGES. DANS LE CAS D'UNITES EQUIPEES D'ENTRAIEMENTS A VITESSE VARIABLE, SE REPORTER AUX INSTRUCTIONS DE L'ENTRAIEMENT POUR DECHARGER LES CONDENSATEURS.

NE PAS RESPECTER CES MESURES DE PRECAUTION PEUT ENTRAINER DES BLESSURES GRAVES POUVANT ETRE MORTELLES.

ADVERTENCIA
¡VOLTAJE PELIGROSO!
DESCONECTE TODA LA ENERGÍA ELÉCTRICA, INCLUIDO LAS DESCONEXIONES REMOTAS Y SIGA LOS PROCEDIMIENTOS DE CIERRE Y ETIQUETADO ANTES DE PROCEDER AL SERVICIO. ASEGURESE DE QUE TODOS LOS CONDENSADORES DEL MOTOR HAYAN DESCARGADO EL VOLTAJE ALMACENADO. PARA LAS UNIDADES CON EJE DE DIRECCIÓN DE VELOCIDAD VARIABLE, CONSULTE LAS INSTRUCCIONES PARA LA DESCARGA DEL CONDENSADOR.

EL NO REALIZAR LO ANTERIORMENTE INDICADO, PODRÍA OCASIONAR LA MUERTE O SERIAS LESIONES PERSONALES.

CAUTION
USE COPPER CONDUCTORS ONLY!
UNIT TERMINALS ARE NOT DESIGNED TO ACCEPT OTHER TYPES OF CONDUCTORS.
FAILURE TO DO SO MAY CAUSE DAMAGE TO THE EQUIPMENT.

ATTENTION
N'UTILISER QUE DES CONDUCTEURS EN COUPE!
LES BORNES DE L'UNITÉ NE SONT PAS CONÇUES POUR RECEVOIR D'AUTRES TYPES DE CONDUCTEURS.
L'UTILISATION DE TOUT AUTRE CONDUCTEUR PEUT ENDOMMAGER L'ÉQUIPEMENT.

PRECAUTION
UTILICE ÚNICAMENTE CONDUCTORES DE COBRE!
LAS TERMINALES DE LA UNIDAD NO ESTÁN DISEÑADAS PARA ACEPTAR OTROS TIPOS DE CONDUCTORES.
SI NO SE HACE, PUEDE OCASIONAR DAÑO AL EQUIPO.



Ph: (858) 292-4773
Fax: (858) 279-0537

HP-6 Thru HP-20
460v 3Ø
9/22/14 R-410A

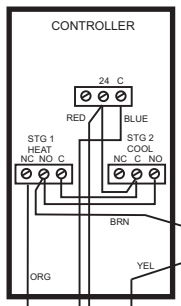

15 & 20 HP JUMPER

J7 BLOCK ON RTM BOARD

- NOTES**
- UNLESS OTHERWISE NOTED, ALL SWITCHES ARE SHOWN AT 25°C (77°F) AT ATMOSPHERIC PRESSURE, AT 50% RELATIVE HUMIDITY, WITH ALL UTILITIES TURNED OFF, AND AFTER A NORMAL SHUTDOWN HAS OCCURRED.
 - DASHED LINES INDICATE RECOMMENDED FIELD WIRING BY OTHERS. DASHED LINE ENCLOSURES AND/OR DASHED DRIVE OUTLINES INDICATE COMPONENTS PROVIDED BY THE FIELD. PHANTOM LINE ENCLOSURES INDICATE ALTERNATE CIRCUITRY OR AVAILABLE SALES OPTIONS. SOLID LINE INDICATES WIRING BY TRANE CO.
 - NUMBERS ALONG THE RIGHT SIDE OF THE SCHEMATIC DESIGNATE THE LOCATION OF CONTACTS BY LINE NUMBER. AN UNDERLINED NUMBER INDICATES A NON-CLOSED CONTACT. AN OPEN ARROWHEAD BELOW THE LINE NUMBER POINTING UPWARD INDICATES A TIMED CONTACT WHICH BEGINS TIMING WHEN ENERGIZED.
 - CONNECTIONS SHOWN ARE FOR 230V/60Hz/3PH UNITS. WHEN 208V/60Hz/3PH OPERATION IS REQUIRED, MOVE WIRES 1E (R) AND 1B (S) FROM 230V TERMINAL ON UNIT TRANSFORMERS (TS1 AND TS2) TO 200V TERMINAL.
 - CONNECTIONS SHOWN ARE FOR 230V/60Hz/3PH UNITS. FOR 460V/60Hz/3PH MODELS, SEE INSET 1A. FOR 575V/60Hz/3PH MODELS, CONNECT WIRE 1E (R) TO THE 575V TERMINAL ON TS1. FOR 380-415V/50Hz/3PH MODELS, SEE INSET 1B.
 - CAUTION: DO NOT JUMPER ACROSS SWITCHES D11, D12, LP1, LP2, HP1 AND HP2 UNDER ANY CIRCUMSTANCES.
 - NOTICE: DO NOT OPERATE OR APPLY POWER TO COMPRESSORS WHILE UNDER A VACUUM. FAILURE TO FOLLOW THESE INSTRUCTIONS WILL RESULT IN COMPRESSOR FAILURE.
 - INSTALL OPTIONAL REMOTE ZONE SENSOR TO TERMINALS S1 AND S2 WHEN REQUIRED. SEE PROGRAMMABLE ZONE SENSOR W/ NSB LITERATURE FOR OPTION CONFIGURATION.
 - THE OAS ON 15T AND 20T UNITS IS CONNECTED AS SHOWN. ON SMALLER UNITS, WIRES S2A AND S2A ARE NOT PRESENT AND THE BROWN LEADS ARE CONNECTED DIRECTLY TO THE RTM.
 - IF EVAPORATOR DEFROST CONTROL (EDC) IS USED ON INDOOR UNIT, REMOVE JUMPER WIRE W1 (R) BETWEEN TERMINALS "CO" AND "R" ON LTB1.
 - SEE HEATER ACCESSORY DIAGRAM FOR DETAILS OF HEATER WIRING.
 - TO ENABLE ELECTRIC HEAT, CUT WIRE 55A (BR) ON P2.
 - TO ENABLE TWO STAGES OF ELECTRIC HEAT, CUT WIRE 49A (BR) ON P1.
 - CONNECTIONS SHOWN ARE FOR 230V/60Hz/3PH UNITS. FOR 460V/60Hz/3PH MODELS, SEE INSET 1A. FOR 575V/60Hz/3PH MODELS, CONNECT WIRE 1E (R) TO THE 575V TERMINAL ON TS1. FOR 380-415V/50Hz/3PH MODELS, SEE INSET 1B.
 - TO ENABLE COMPRESSOR LEAD/LAG OPERATION, CUT WIRE 68D (BL).

TRANE
CONDENSER UNIT - HEAT PUMP
617/51/51/71 TALL UNIT TEST 6
10/20T/380-415V/50Hz/60Hz / 380-415V/50Hz

DATE: 11/11/14
DRAWN BY: J. J. JENSEN
CHECKED BY: J. J. JENSEN
DATE: 11/11/14

REVISED BY: J. J. JENSEN
DATE: 11/11/14

REVISED BY: J. J. JENSEN
DATE: 11/11/14

REVISED BY: J. J. JENSEN
DATE: 11/11/14

MT-9 & MT-10 SPECIFICATION

FOR INDOOR OR OUTDOOR FRESH AND SALT WATER APPLICATIONS

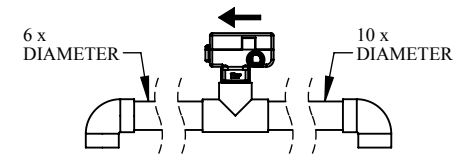
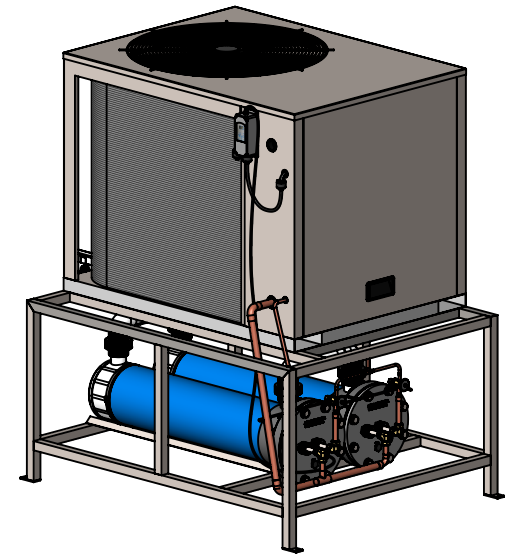
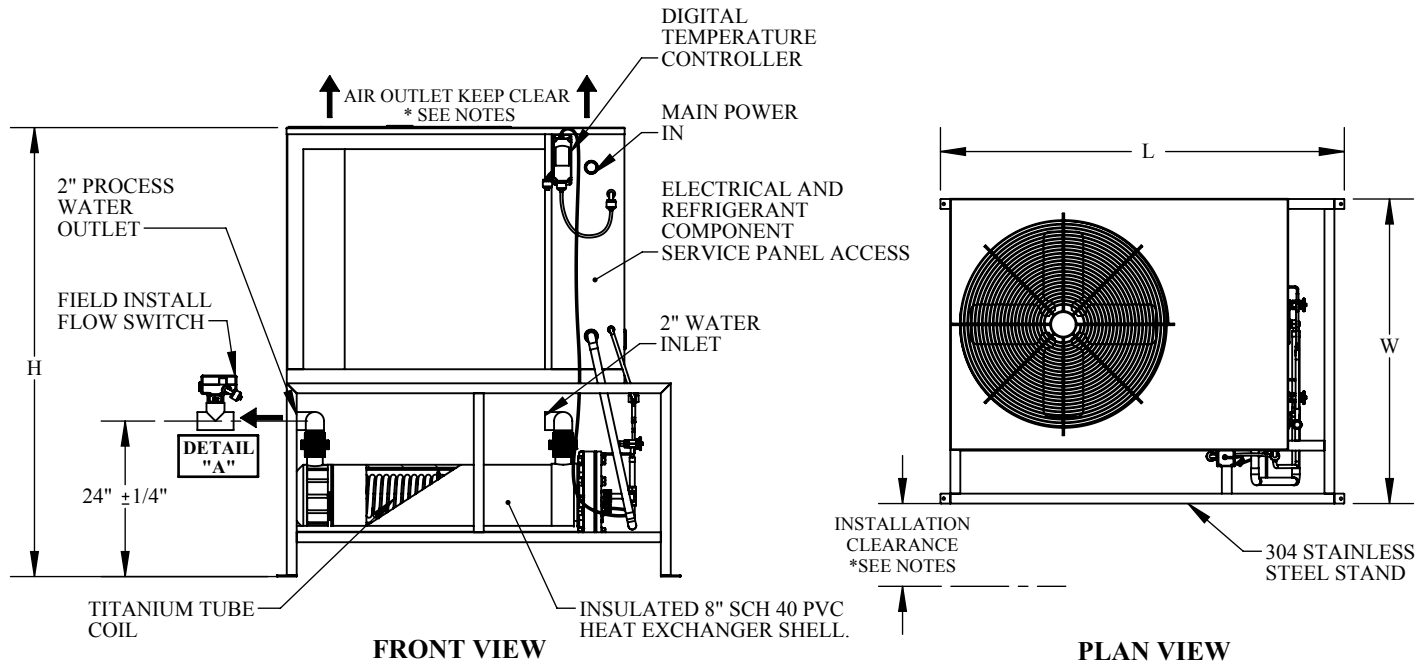

IMPORTANT!
DETAIL "A"
 • FLOW SWITCH MUST BE FIELD INSTALLED HORIZONTALLY WITH NO LESS THAN 10 TIMES THE DIAMETER OF STRAIGHT PIPE ON THE INLET SIDE AND NO LESS THAN 6 TIMES THE DIAMETER ON THE OUTLET SIDE.

- OPTIONS:**
- SCH 80 SHELL CONSTRUCTION.
 - 316 STAINLESS STEEL STAND AND HARDWARE.
 - LOW AMBIENT HEAD PRESSURE CONTROL.
 - HAIL GUARDS TO PROTECT CONDENSER FINS.
 - COASTAL MARINE CONDENSER COATING.

MULTI-TEMP WATER CHILLERS									
MODEL NO.	NOMINAL TONS / BTUH / KW	VOLTS / PHASE	AMPS RLA / LRA	WATER FLOW RATE (GPM)	AIR OULET (CFM)	L	W	H	SHIPPING WEIGHT (-lbs.)
MT-9	7.5 / 90K / 26.3	208 - 240 / 3	28 / 164	60 / 120	6530	51"	42"	68"	670
MT-9-460	7.5 / 90K / 26.3	460 / 3	15 / 100	60 / 120	6530	51"	42"	68"	675
MT-10	10 / 120K / 35.1	208 - 230 / 3	35 / 225	60 / 120	9800	61"	46"	68"	815
MT-10-460	10 / 120K / 35.1	460 / 3	19 / 114	60 / 120	9800	61"	46"	68"	815

*NORMAL OPERATING AMBIENT AIR TEMPERATURE: 50°F - 115°F.
 *ADD LOW AMBIENT HEAD PRESSURE CONTROL FOR OPERATING IN AMBIENT AIR TEMPERATURES FROM 0°F TO 50°F.
 CONSULT AQUA LOGIC IF OPERATING AT TEMPERATURES OUTSIDE THESE RANGES.

- *NOTES:**
- TOP DISCHARGE AREA SHOULD BE UNRESTRICTED FOR 100 INCHES MINIMUM.
 - UNIT SHOULD BE PLACED SO ROOF RUN-OFF WATER DOES NOT POUR DIRECTLY ON UNIT.
 - MINIMUM CLEARANCE FOR PROPER OPERATION IS 36 INCHES FROM WALLS, SHRUBBERY, FENCES, ETC.
 - MINIMUM CLEARANCE BETWEEN ADJACENT UNITS IS 72 INCHES.
 - ALL DIMENSIONS ARE APPROXIMATE AND CAN CHANGE AT ANY TIME.



9558 Camino Ruiz, San Diego, CA 92126

DRAWING # PDF-0051 SHEET TITLE

MT-9 & MT-10 SPECIFICATIONS

* COPYRIGHT * These drawings including design idea and construction techniques herein are the sole property of Aqua Logic Inc. They shall not be revised, copied, or reproduced in any manner without the written consent of Aqua Logic Inc.		DESCRIPTION MULTI TEMP AIR COOLED WATER CHILLER	DATE 11/12/2015	REVISION	SCALE 1:29	SHEET # 1 OF 1
DRAWN BY Arnaldo Guzman						

MT-15 & MT-20 SPECIFICATION

FOR INDOOR OR OUTDOOR FRESH AND SALT WATER APPLICATIONS

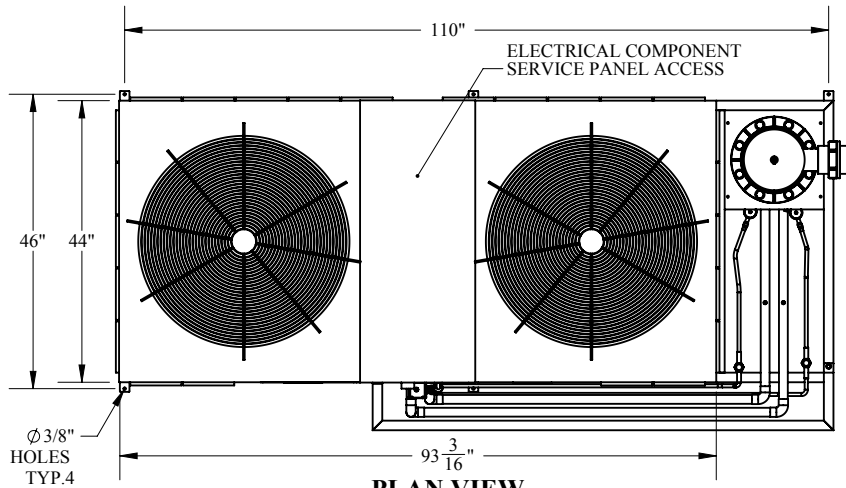

PLAN VIEW

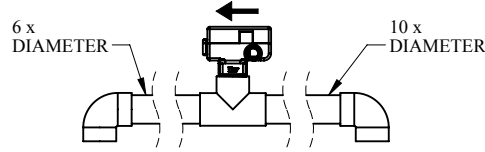

IMPORTANT!
DETAIL "A"

· FLOW SWITCH MUST BE FIELD INSTALLED HORIZONTAL WITH NO LESS THAN 10 TIMES THE DIAMETER OF STRAIGHT PIPE ON THE INLET SIDE AND NO LESS THAN 6 TIMES THE DIAMETER ON THE OUTLET SIDE.

***NOTES:**

- AIR OUTLET DISCHARGE SHOULD BE UNRESTRICTED AT LEAST 100 INCHES ABOVE THE UNIT.
- UNIT SHOULD BE PLACED SO ROOF RUN-OFF WATER DOES NOT POUR DIRECTLY ON UNIT.
- MINIMUM CLEARANCE FOR PROPER OPERATION IS 36 INCHES FROM WALLS, SHRUBBERY, FENCES, ETC.
- MINIMUM CLEARANCE BETWEEN ADJACENT UNITS IS 72 INCHES.
- ALL DIMENSIONS ARE APPROXIMATE AND CAN CHANGE AT ANY TIME.

OPTIONS:

- SCH 80 SHELL CONSTRUCTION.
- 316 STAINLESS STEEL STAND AND HARDWARE.
- LOW AMBIENT HEAD PRESSURE CONTROL (USE IN 50 °F WEATHER AND BELOW).
- HAIL GUARDS TO PROTECT CONDENSER FINS.
- COASTAL MARINE CONDENSER COATING.

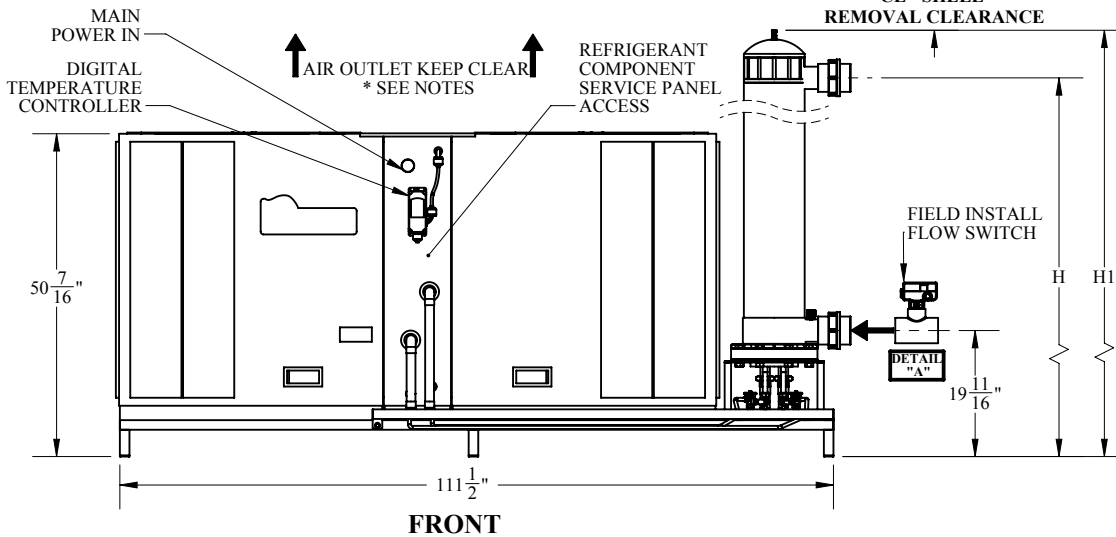

FRONT

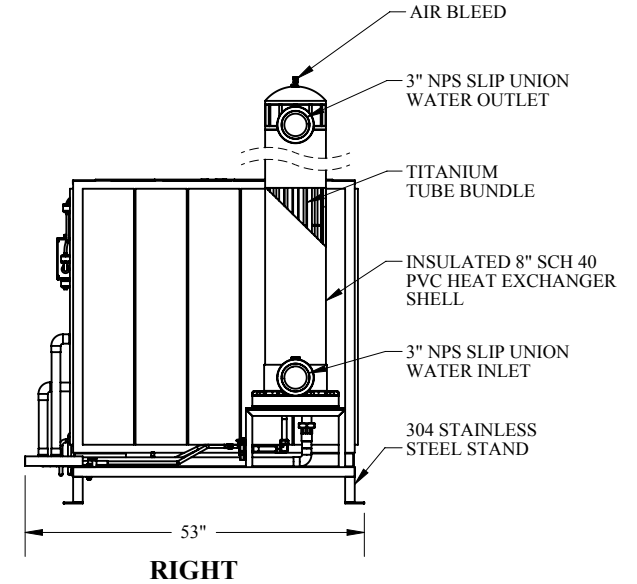

RIGHT

MULTI-TEMP WATER CHILLERS												
MODEL NO.	NOMINAL CAPACITY TONS / BTUH / KW	VOLTS / PHASE	AMPS RLA / LRA	UNIT OPERATING VOLTAGE RANGE	MINIMUM CIRCUIT AMPACITY	MAXIMUM FUSE SIZE OR MAXIMUM CIRCUIT BREAKER (a)	WATER FLOW RATE (GPM)	AIR OULET EA. FAN (CFM)	H1	H	CL SHELL	SHIPPING WEIGHT (-lbs.)
MT-15	15 / 180K / 52.7	208 - 230 / 3	50 / 164	187 - 253	66.3	80	120 / 180	9750	78"	72 1/2"	63 1/2"	1559
MT-15-460	15 / 180K / 52.7	460 / 3	25 / 100	414 - 506	33.4	40	120 / 180	9750	78"	72 1/2"	63 1/2"	1559
MT-20	20 / 240K / 70.2	208 - 230 / 3	78 / 267	187 - 253	98	110	120 / 180	9750	91"	83 1/2"	75 1/2"	1714
MT-20-460	20 / 240K / 70.2	460 / 3	40 / 142	414 - 506	46.9	60	120 / 180	9750	91"	83 1/2"	75 1/2"	1714

-(a) HACR TYPE CIRCUIT BREAKER PER NEC

* COPYRIGHT *
These drawings including design idea and construction techniques herein are the sole property of Aqua Logic Inc. They shall not be revised, copied, or reproduced in any manner without the written consent of Aqua Logic Inc.

DESCRIPTION
MULTI TEMP AIR COOLED WATER CHILLER

DRAWN BY	DATE	REVISION	SCALE	SHEET #
Arnaldo Guzman	11/12/2015		1:30	1 OF 1



9558 Camino Ruiz, San Diego, CA 92126

DRAWING # PDF-0305 SHEET TITLE

MT-15 & MT-20 SPECIFICATIONS

HP-6 THRU HP-7 SPECIFICATION

FOR INDOOR OR OUTDOOR FRESH AND SALT WATER APPLICATIONS

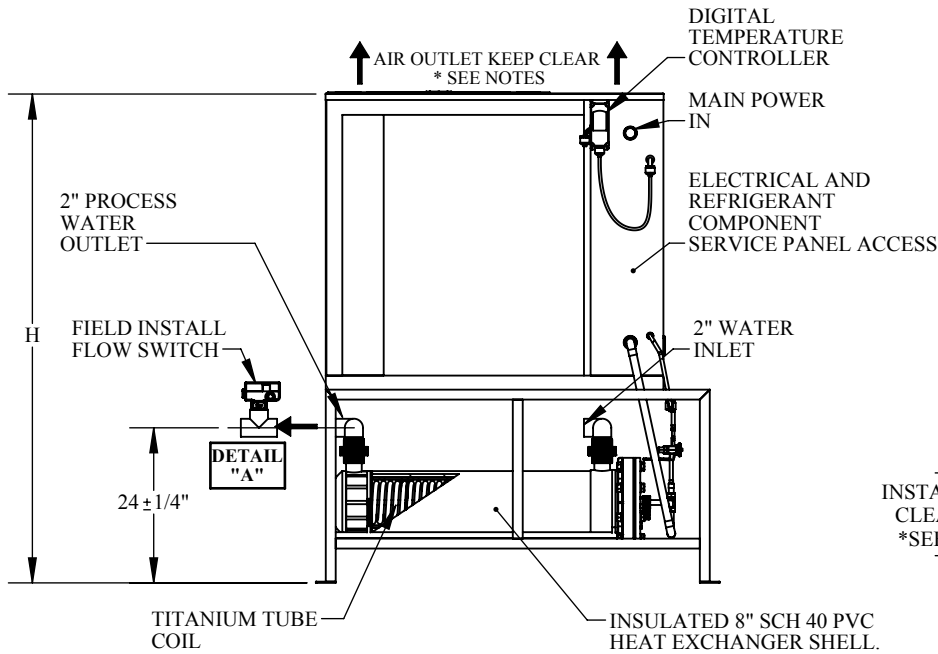

FRONT VIEW

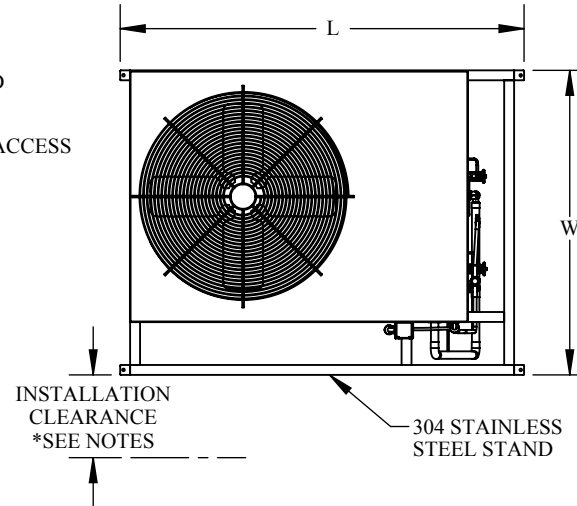

PLAN VIEW

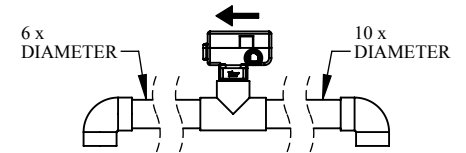
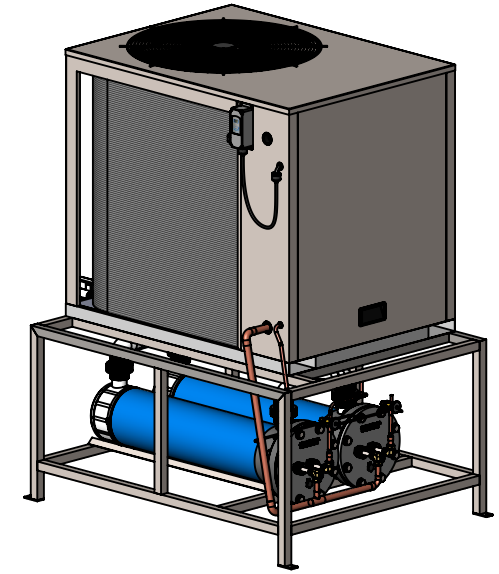

IMPORTANT!
DETAIL "A"
 · FLOW SWITCH MUST BE FIELD INSTALLED HORIZONTALLY WITH NO LESS THAN 10 TIMES THE DIAMETER OF STRAIGHT PIPE ON THE INLET SIDE AND NO LESS THAN 6 TIMES THE DIAMETER ON THE OUTLET SIDE.

OPTIONS:
 · SCH 80 SHELL CONSTRUCTION.
 · 316 STAINLESS STEEL STAND AND HARDWARE.
 · LOW AMBIENT HEAD PRESSURE CONTROL ON COOLING MODE ONLY.
 · HAIL GUARDS TO PROTECT CONDENSER FINS.
 · COASTAL MARINE CONDENSER COATING.

TITAN HEAT PUMPS									
MODEL NO.	NOMINAL TONS / BTUH / KW	VOLTS / PHASE	AMPS RLA / LRA	WATER FLOW RATE (GPM)	AIR OULET (CFM)	L	W	H	SHIPPING WEIGHT (LBS)
HP-6	7.5 / 90K / 26.3	208 - 230 / 3	29 / 172	60 / 120	8200	51"	42"	68"	670
HP-6-460	7.5 / 90K / 26.3	460 / 3	15 / 94	60 / 120	8200	51"	42"	68"	675
HP-7	10 / 120K / 35.1	208 - 230 / 3	40 / 278	60 / 120	8200	61"	46"	74"	850
HP-7-460	10 / 120K / 35.1	460 / 3	15 / 90	60 / 120	8200	61"	46"	74"	850

*NORMAL OPERATING AMBIENT AIR TEMPERATURE: 50°F - 115°F.
 *ADD LOW AMBIENT HEAD PRESSURE CONTROL FOR OPERATING IN AMBIENT AIR TEMPERATURES FROM 0°F TO 50°F.
 CONSULT AQUA LOGIC IF OPERATING AT TEMPERATURES OUTSIDE THESE RANGES.

***NOTES:**
 · TOP DISCHARGE AREA SHOULD BE UNRESTRICTED FOR 100 INCHES MINIMUM.
 · UNIT SHOULD BE PLACED SO ROOF RUN-OFF WATER DOES NOT POUR DIRECTLY ON UNIT.
 · RECOMMENDED MINIMUM CLEARANCE FOR PROPER OPERATION AND MAINTENANCE IS 36" FROM WALLS, SHRUBBERY, FENCES, ETC.
 · MINIMUM CLEARANCE BETWEEN ADJACENT UNITS IS 72 INCHES.
 · ALL DIMENSIONS ARE APPROXIMATE AND CAN CHANGE AT ANY TIME.



9558 Camino Ruiz, San Diego, CA 92126

DRAWING # PDF-0238 SHEET TITLE HP-6 THRU HP-7 SPECIFICATIONS

* COPYRIGHT * These drawings including design idea and construction techniques herein are the sole property of Aqua Logic Inc. They shall not be revised, copied, or reproduced in any manner without the written consent of Aqua Logic Inc.		DESCRIPTION TITAN HEAT PUMP AIR COOLED		DRAWN BY Arnaldo Guzman		DATE 11/13/2015		REVISION		SCALE		SHEET # 1 OF 1	
---	--	---	--	----------------------------	--	--------------------	--	----------	--	-------	--	-------------------	--

HP-15 & HP-20 SPECIFICATION

FOR INDOOR OR OUTDOOR FRESH AND SALT WATER APPLICATIONS

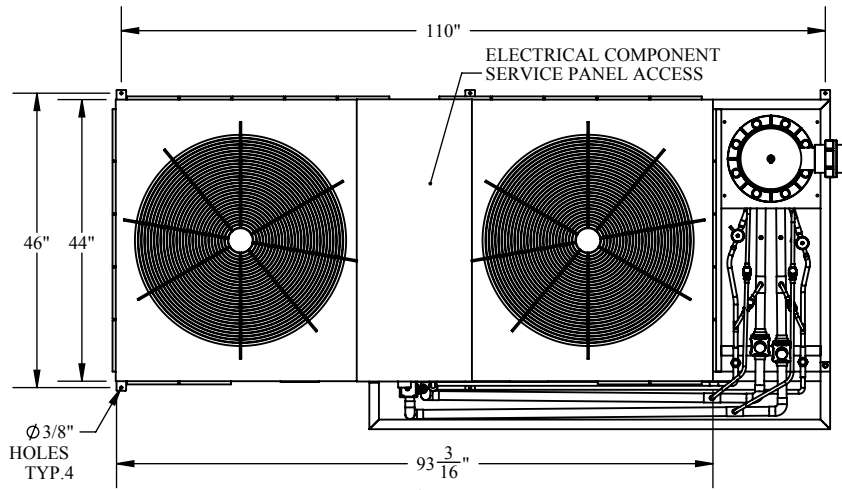

PLAN VIEW

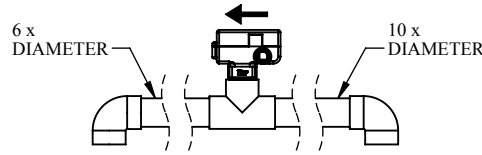

IMPORTANT!
DETAIL "A"

· FLOW SWITCH MUST BE FIELD INSTALLED HORIZONTAL WITH NO LESS THAN 10 TIMES THE DIAMETER OF STRAIGHT PIPE ON THE INLET SIDE AND NO LESS THAN 6 TIMES THE DIAMETER ON THE OUTLET SIDE.

***NOTES:**

- AIR OUTLET DISCHARGE SHOULD BE UNRESTRICTED AT LEAST 100 INCHES ABOVE THE UNIT.
- UNIT SHOULD BE PLACED SO ROOF RUN-OFF WATER DOES NOT POUR DIRECTLY ON UNIT.
- MINIMUM CLEARANCE FOR PROPER OPERATION IS 36 INCHES FROM WALLS, SHRUBBERY, FENCES, ETC.
- MINIMUM CLEARANCE BETWEEN ADJACENT UNITS IS 72 INCHES.
- ALL DIMENSIONS ARE APPROXIMATE AND CAN CHANGE AT ANY TIME.

OPTIONS:

- SCH 80 SHELL CONSTRUCTION.
- 316 STAINLESS STEEL STAND AND HARDWARE.
- LOW AMBIENT HEAD PRESSURE CONTROL (USE IN 50 °F WEATHER AND BELOW).
- HAIL GUARDS TO PROTECT CONDENSER FINS.
- COASTAL MARINE CONDENSER COATING.

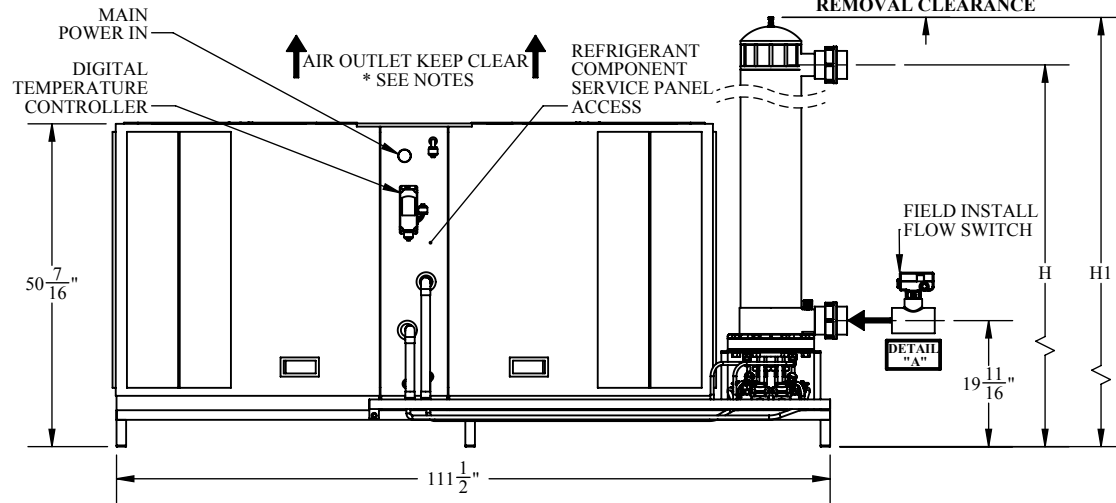

FRONT

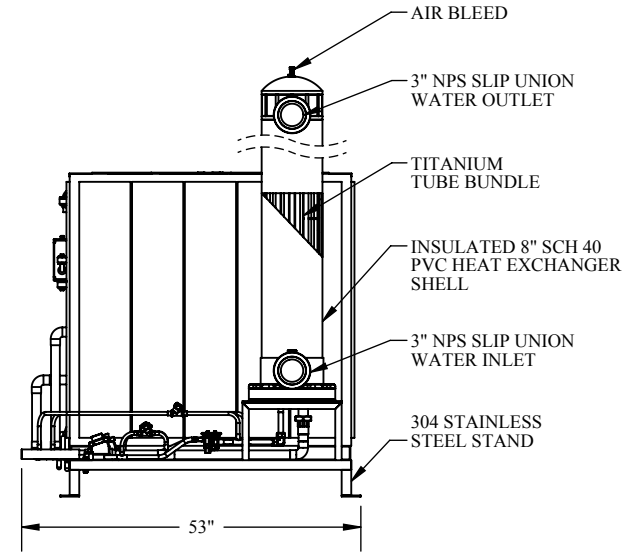

RIGHT

TITAN HEAT PUMP													
MODEL NO.	NOMINAL CAPACITY TONS / BTUH / KW	COP	VOLTS / PHASE	AMPS RLA / LRA	UNIT OPERATING VOLTAGE RANGE	MINIMUM CIRCUIT AMPACITY	MAXIMUM FUSE SIZE OR MAXIMUM CIRCUIT BREAKER (a)	WATER FLOW RATE (GPM)	AIR OULET EA. FAN (CFM)	H1	H	CL SHELL	SHIPPING WEIGHT (-lbs.)
HP-15	15 / 180K / 52.7	3.2	208 - 230 / 3	50 / 164	187 - 253	66.3	80	120 / 180	9750	78"	72 1/2"	63 1/2"	1578
HP-15-460	15 / 180K / 52.7	3.2	460 / 3	25 / 100	414 - 506	33.4	40	120 / 180	9750	78"	72 1/2"	63 1/2"	1578
HP-20	20 / 240K / 70.2	2.9	208 - 230 / 3	78 / 267	187 - 253	98	110	120 / 180	9750	91"	83 1/2"	75 1/2"	1657
HP-20-460	20 / 240K / 70.2	2.9	460 / 3	40 / 142	414 - 506	46.9	60	120 / 180	9750	91"	83 1/2"	75 1/2"	1657

-(a) HACR TYPE CIRCUIT BREAKER PER NEC

* COPYRIGHT *
These drawings including design idea and construction techniques herein are the sole property of Aqua Logic Inc. They shall not be revised, copied, or reproduced in any manner without the written consent of Aqua Logic Inc.

DESCRIPTION
TITAN HEAT PUMP AIR COOLED

DRAWN BY	DATE	REVISION	SCALE	SHEET #
Arnaldo Guzman	11/13/2015			1 OF 1



9558 Camino Ruiz, San Diego, CA 92126

DRAWING # PDF-0308 SHEET TITLE HP-15 THRU HP-20 SPECIFICATIONS